

OFFENSIVE FORMATION
NUMBERING SYSTEM

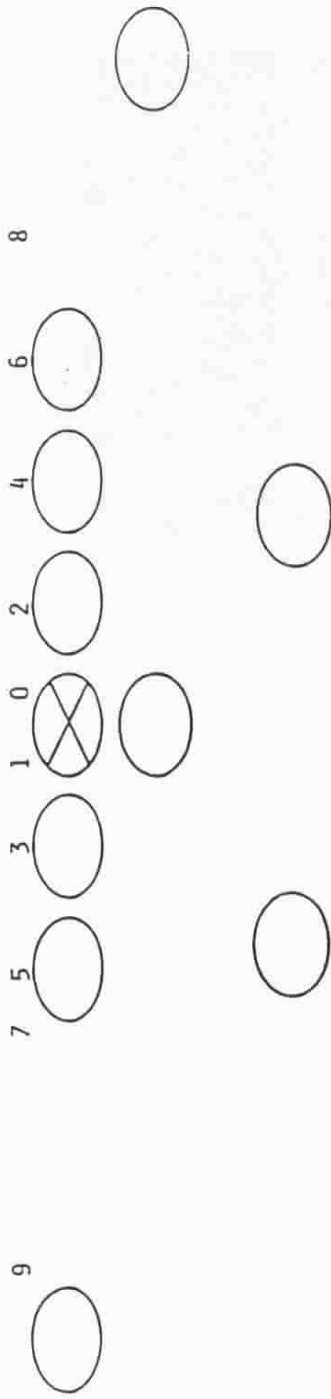

Running Backs' Alignment - Split inside leg of offensive tackles. Heels are at 5 yards.
Line Splits - Center - Guard split is 2 feet. Guard - tackle split is 2 feet. Tackle
tight end split is 2-3 feet.
Flanker and X Alignment - 8 to 12 yards.

THE HUDDLE PROCEDURE

THE HUDDLE

*Ball

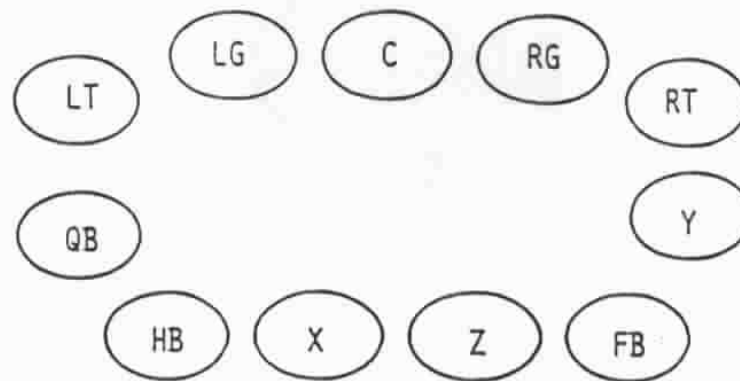

FORMING AND BREAKING THE HUDDLE:

1. Center always sets up huddle eight yards from ball. Set up quickly.
2. Huddle is oval type with QB's left side to LOS.
3. Line up quickly with hands on knees in position to see and hear the quarterback.
4. Quarterback has complete control of huddle.
5. You will receive the following information in the huddle:
 - A. Formation (motion possible)
 - B. Play
 - C. Blocking (possible)
 - D. Pass pattern (possible)
 - E. Snap number
6. When you do not hear what is said, call check.
7. "Ready-Break" is the signal to leave the huddle - clap hands - linemen turn to outside and go to LOS quickly.
8. The huddle reflects the attitude of each man and the team - keep huddle sharp.
9. Quarterback - Do not call "Ready-Break" until the receivers have left the huddle.

IN THE HUDDLE.....

QB does all the talking.

QB will give the following information:

1. Formation (i.e. Red, Brown, Green, Blue, etc.)
2. Formation Adjustments (i.e. Tight, Close, Y Deep, etc.)
3. Motions or Shifts (i.e. "Z" Right, "C" Left, Y Motion, etc.)
4. Play Number (i.e. 65, 20, 98, etc.)
5. Play Terms (i.e. Power, X Hook, etc.)
6. Snap Count (i.e. On two, On set, On first sound, etc.)
7. Ready-Break

Here's How it Sounds....

1. Red Right Slot, 24 Double Square Out, On set - Ready-Break.
2. Brown Left Slot, "Z" Left, 64, On one - Ready-Break.
3. Double Wing Right, 78 X Hook, On first sound - Ready-Break.

Note: Ball may be snapped on any of the following snap counts:

- A. 1st sound
- B. Set
- C. One (1st "Hut")
- D. Two (2nd "Hut")
- E. Three (3rd "Hut" - QB will try to draw the defense off sides)

AT THE LINE OF SCRIMMAGE (L.O.S.)....

1. QB calls color and number to each side
2. QB calls defensive front
3. QB pauses and completes snap count as follows: "Set" (pause)
"Hut" - "Hut" "Hut"
4. When QB calls the snap count on three (3), he will try to draw the defense offside on the 2nd "Hut" by accenting the count - pauses - and then calls the third "Hut." The team is alert for the "staggered count" every time the QB calls the play "On Three (3)"
5. Audibles may be called regardless of the snap count. If the count is "1st Sound," the QB audibles before he puts his hands under the center - the snap count then changes.

Here's How it Sounds.....

1. On 1st Sound -
"Pro" (ball is snapped on 1st thing QB shouts)
2. On Set -
"Color - Number - Color - Number - 43 - Set"
3. On One -
"Color - Number - Color - Number - 34 - Set - Hut"
4. On Two -
"Color - Number - Color - Number - 25 - Set - Hut - Hut"
5. On Three -
"Color - Number - Color - Number - 53 - Set - Hut - Hut -----
----- Hut"

AUDIBLE AT THE L.O.S.....

1. A change of play at the LOS may come at any time. If the center does not feel pressure, he does not snap the ball.
2. Team aligns at LOS in three point stance.
3. If QB wants to change the play called in the huddle, he calls the live color and the audible number. He pauses and repeats color and number again. QB pauses and continues the normal snap count.
4. All audibles will go on a predetermined count (set).
6. If no audible is needed as in two minute offense, no color and audible number are called. QB simply comes to LOS and begins the cadence by calling the defensive front. The QB will inform the team that he is in a "No dummy audible" mode though he may still call a live audible if needed.

Here's How it Sounds....

(Assume Red is the live color)

(QB at LOS, but hands not under center)

(Team in three point stance)

1. QB Audible at LOS: (on Set)
Red 78 (pause) Red 78 (pause) 43 (pause) Set.
2. QB Dummy Audible at LOS: (on One)
White 50 (pause) White 50 (pause) 34 (pause) Set (pause) Hut.
3. QB not using the audible at LOS: (on Three)
53 (pause) Set (pause) Hut-Hut-----Hut.
4. QB not using audible at LOS: (on 1st Sound)
"Pro" (ball is snapped on 1st thing QB shouts).

DEFENSIVE FRONTS

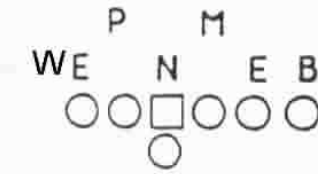

34

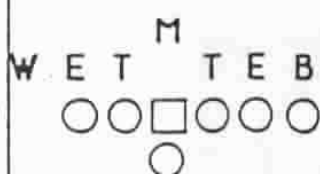

43

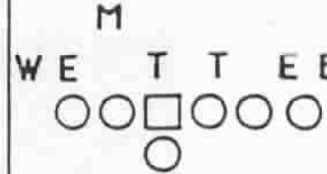

50

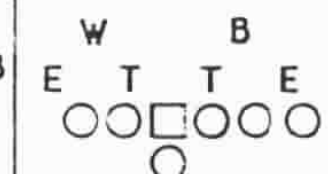

42(NIK)

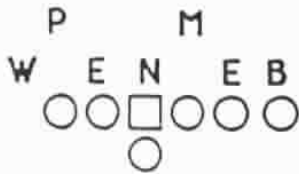

35

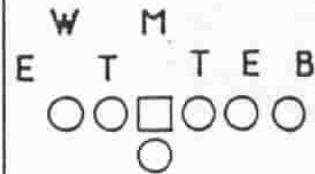

45

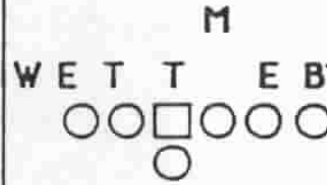

20

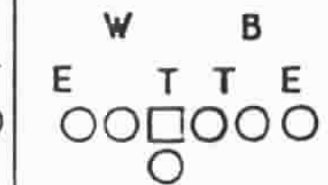

42 KING



37

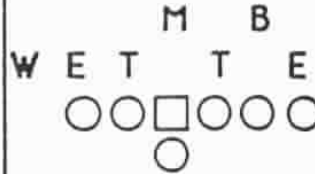

47



25

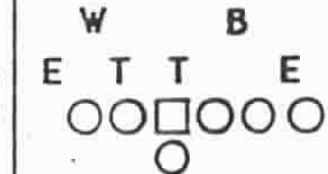

42 QUEEN

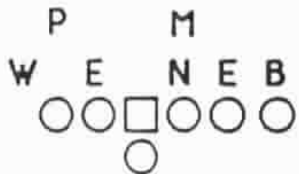

34 +

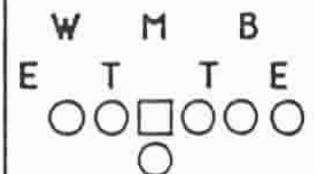

49

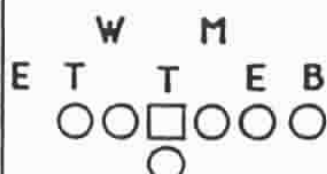

23



NAVAJO



41

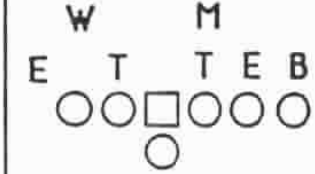

44

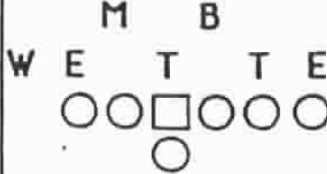

53

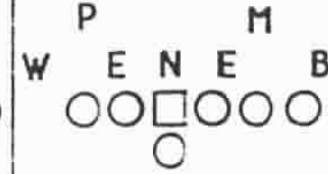

39

"BASE"

PERSONNEL GROUPINGS

"TIGER"

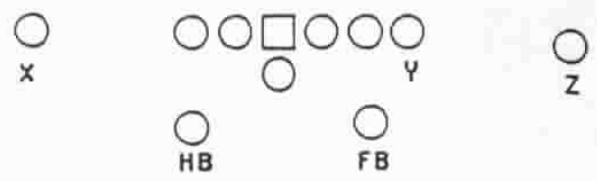

2 RB's, 1 TE, 2 WR's

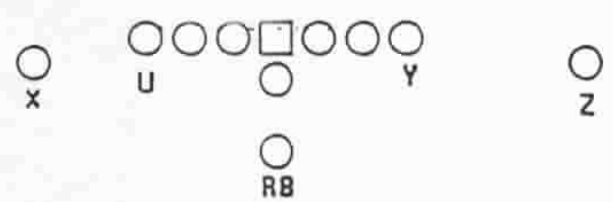

1 RB, 2 TE's, 2 WR's

"E"

"ZEBRA"

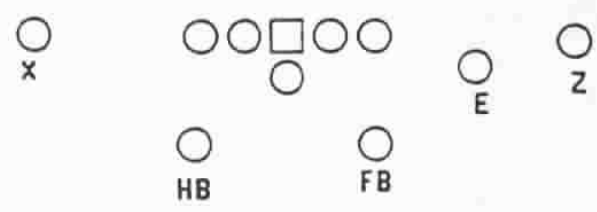

2 RB's, 0 TE's, 3 WR's

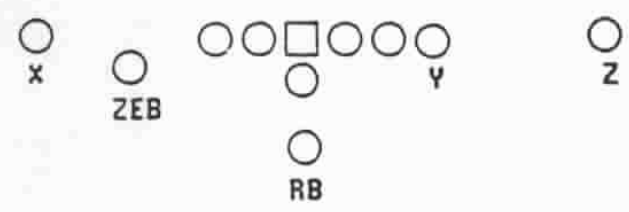

1 RB, 1 TE, 3 WR's

"U"

"EAGLE"

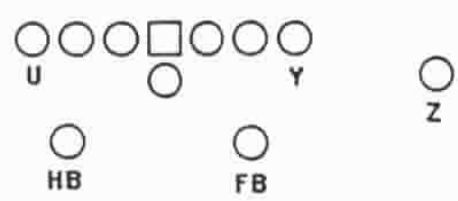

2 RB's, 2 TE's, 1 WR

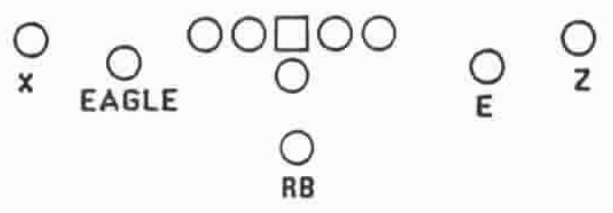

1 RB, 0 TE's, 4 WR's

"Y"

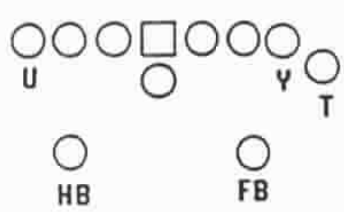

2 RB's, 3 TE's, 0 WR's

BASIC BACKFIELD SETS



RED RIGHT



CHANGE RIGHT



BROWN RIGHT



BLUE RIGHT



GREEN RIGHT



GREEN RIGHT STRONG



GREEN RIGHT NEAR

BACKFIELD-MOTIONS

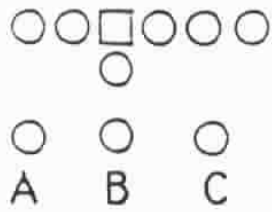

RED RIGHT 'A' RIGHT

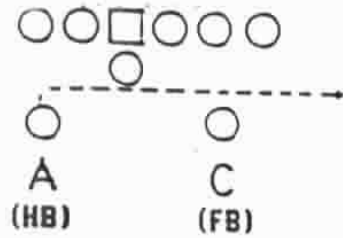

RED RIGHT 'C' LEFT

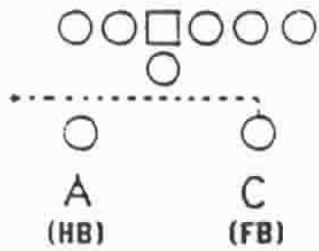

BLUE RIGHT 'C' LEFT

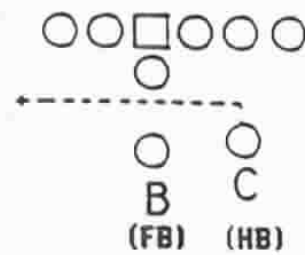

BROWN RIGHT 'B' RIGHT

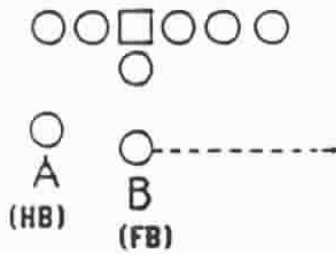

DOUBLE WING RIGHT LURK 'A' RIGHT

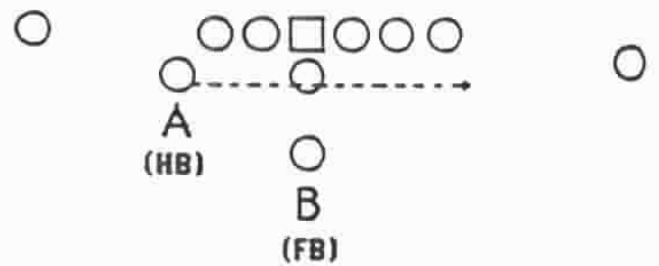

DOUBLE WING RIGHT HB COUNTER MOTION

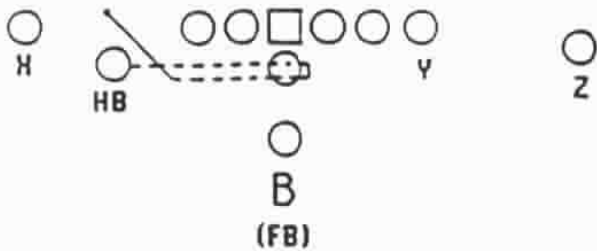

FAR DOUBLE WING RIGHT HB SHORT

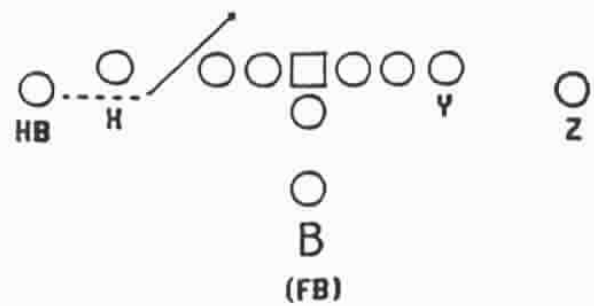

HALFBACK ALIGNMENTS

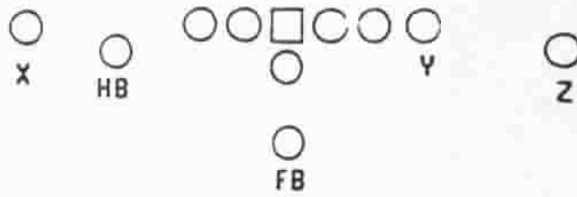

DOUBLE WING RIGHT

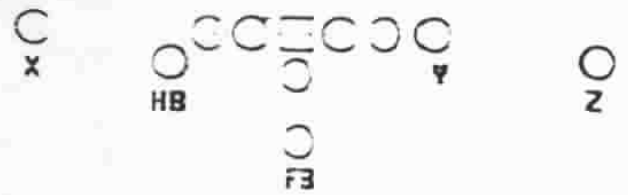

DOUBLE WING RIGHT "LURK"

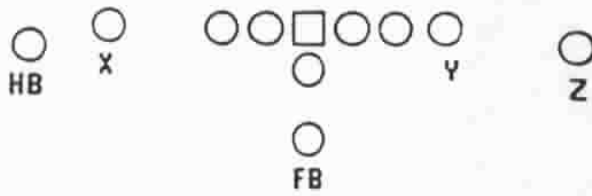

"FAR" DOUBLE WING RIGHT

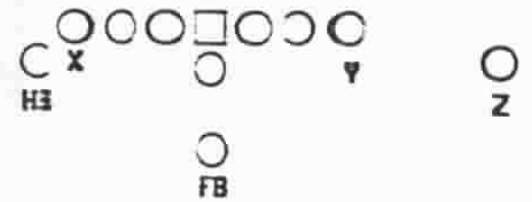

HB "SOUTH" RIGHT

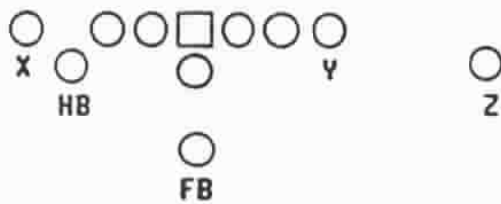

HB "NORTH" RIGHT

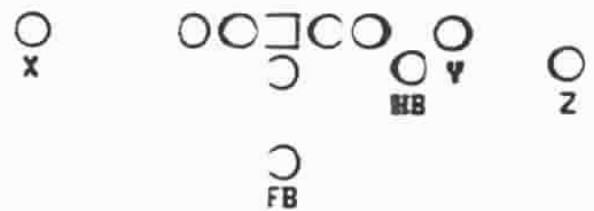

HB "EAST" RIGHT

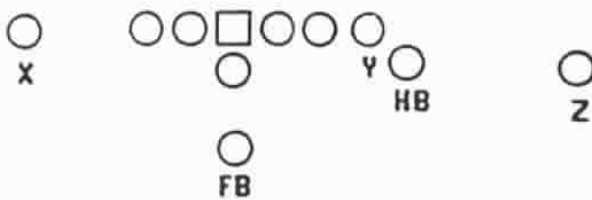

HB "WEST" RIGHT

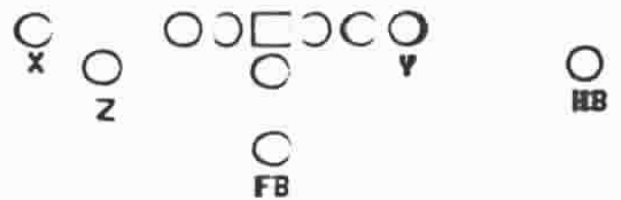

HB FAR WEST RIGHT SLOT

FULLBACK ALIGNMENTS

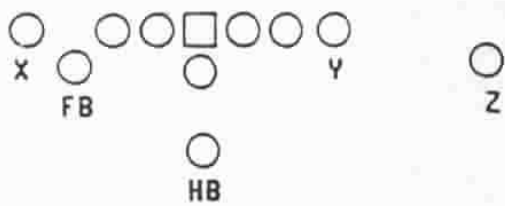

FB "NORTH" RIGHT

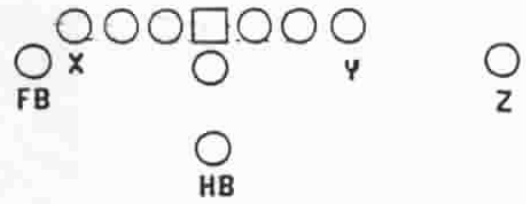

FB "SOUTH" RIGHT

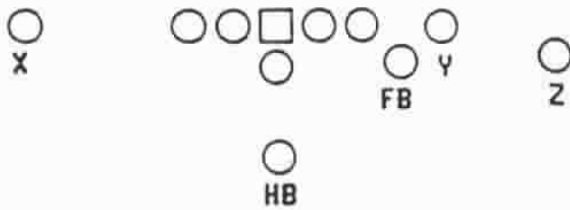

FB "EAST" RIGHT

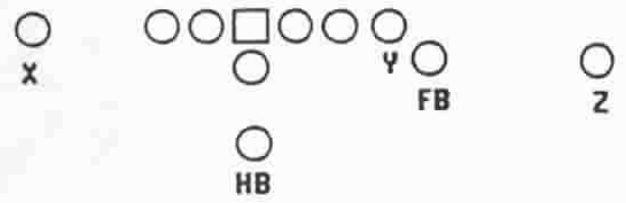

FB "WEST" RIGHT

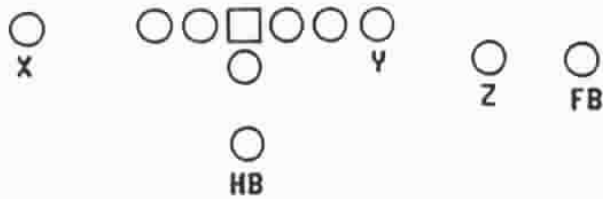

FB FAR RIGHT WEST

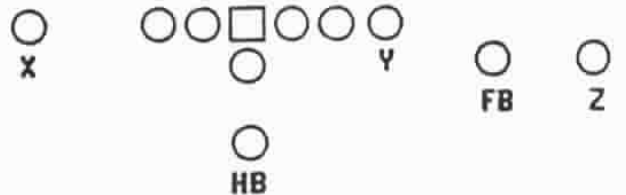

FB TRIPS RIGHT

TE BASIC ALIGNMENTS (Y)

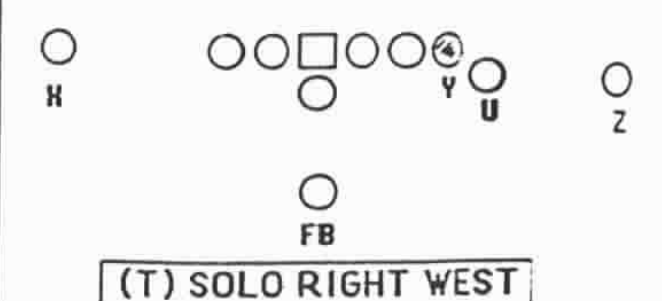
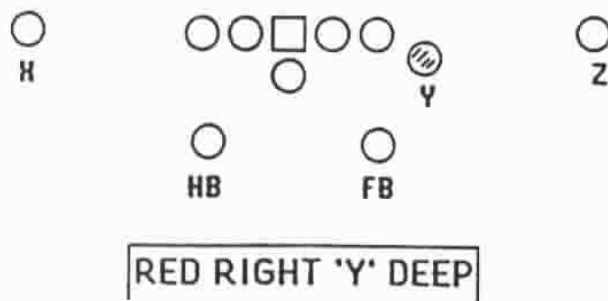
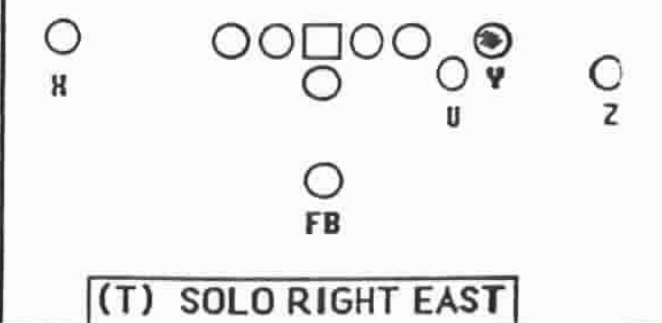
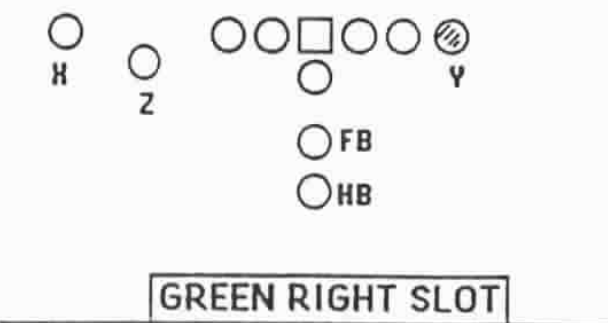
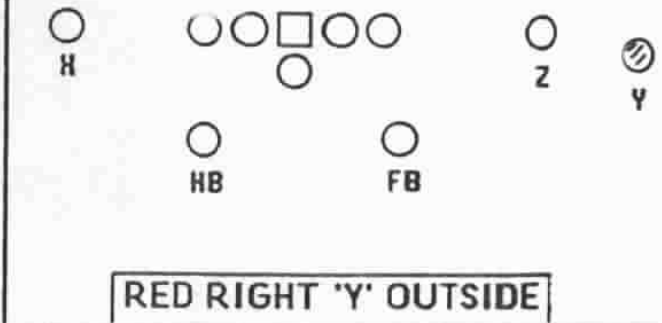
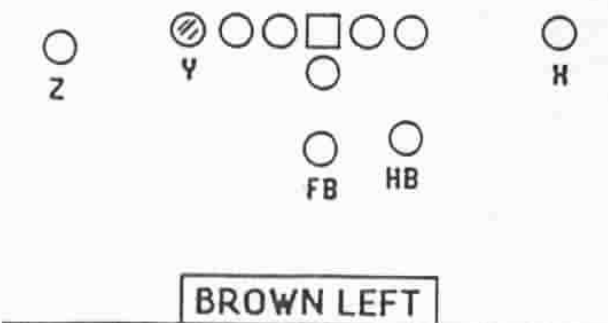
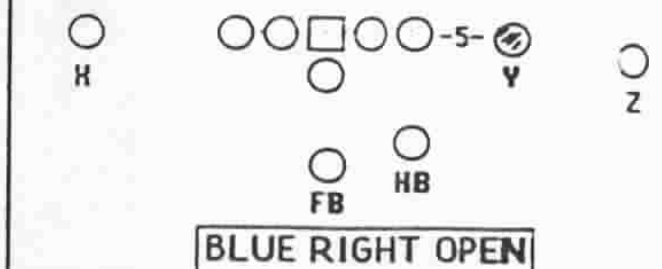
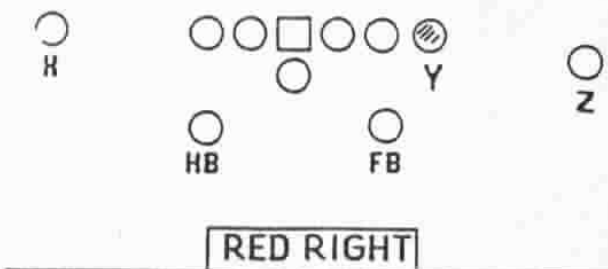

TE (Y) MOTIONS

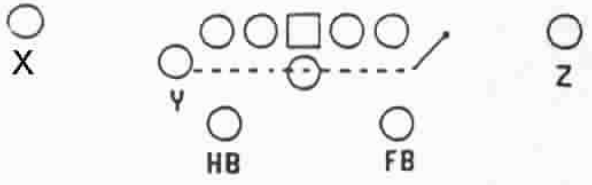

RED RIGHT 'Y' MOTION

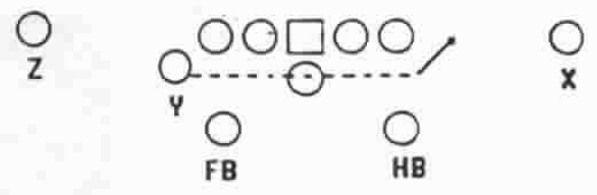

RED LEFT 'Y' RIGHT

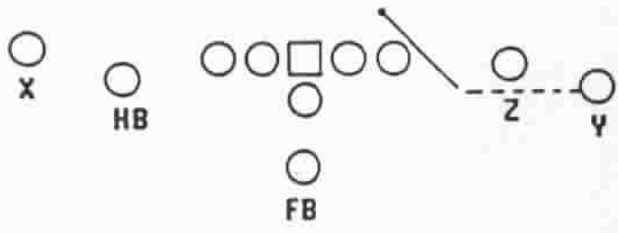

DOUBLE WING RIGHT 'Y' SHORT

FLANKER (Z) ALIGNMENTS

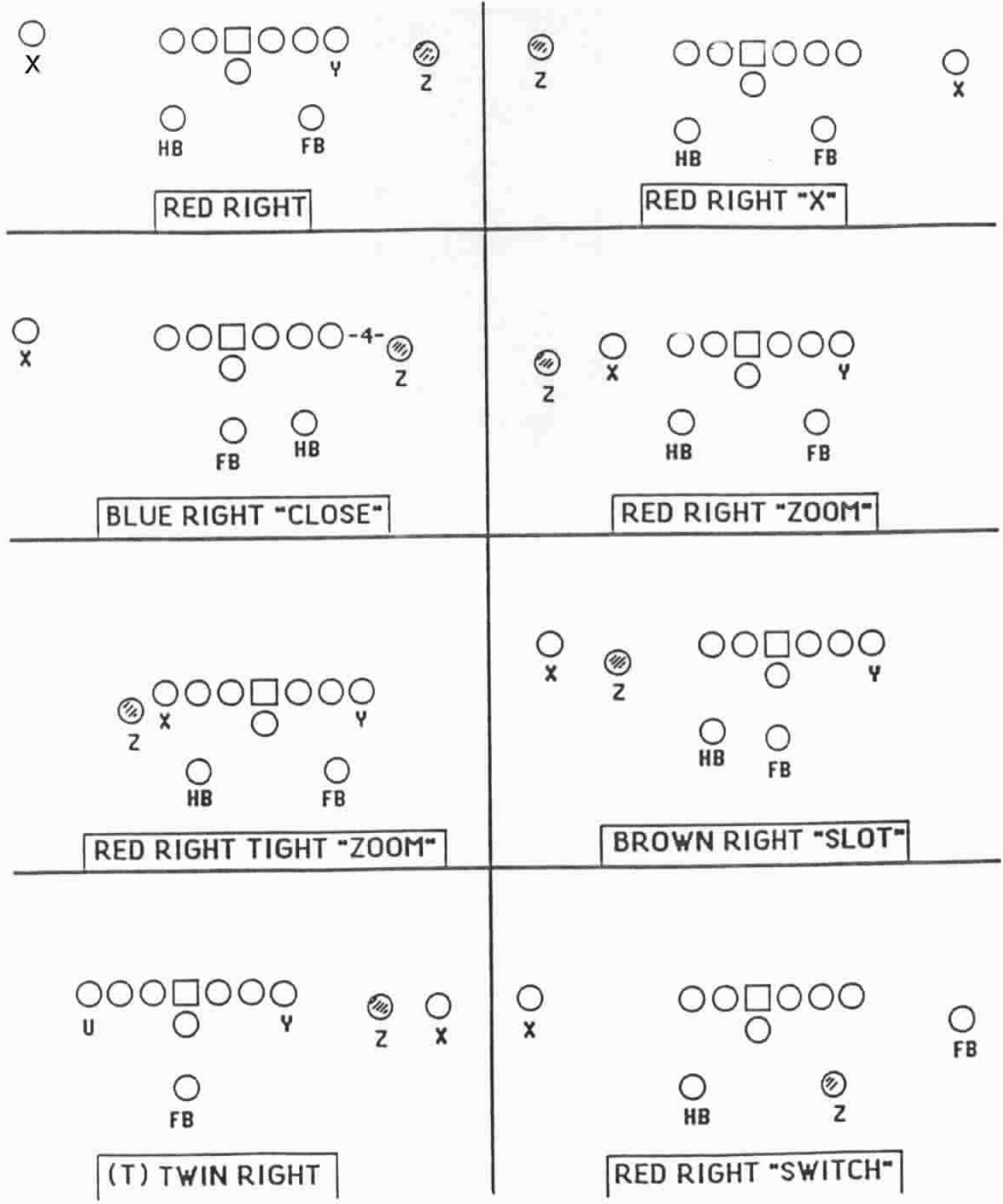

FLANKER (Z) MOTIONS

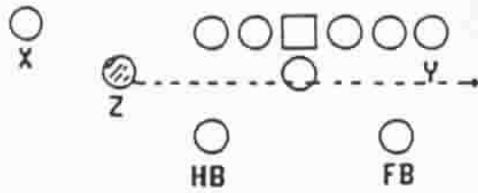

RED RIGHT SLOT 'F' RIGHT

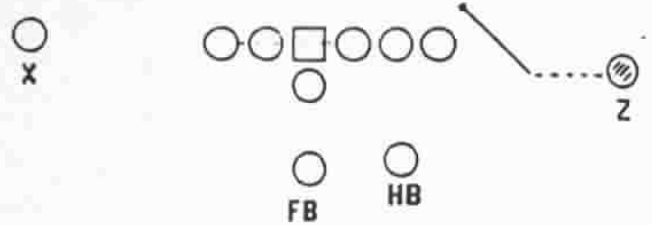

BLUE RIGHT 'F' SHORT

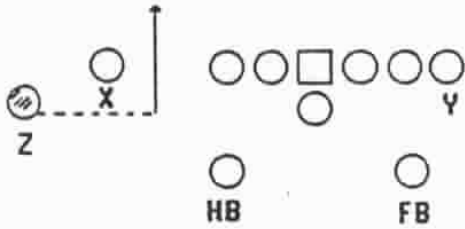

RED RIGHT "ZOOM SHORT"

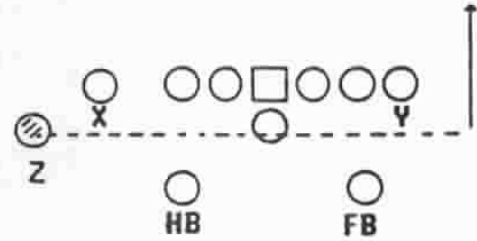

RED RIGHT "ZOOM MOTION"

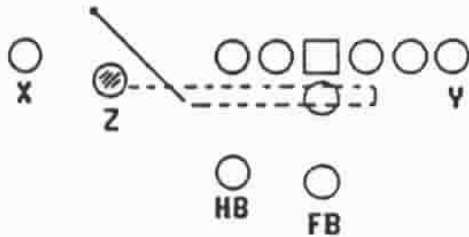

BROWN RIGHT SLOT
'F' COUNTER MOTION

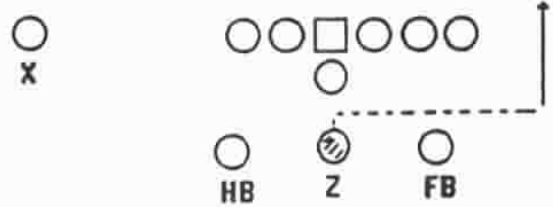

RED RIGHT 'Z' RIGHT

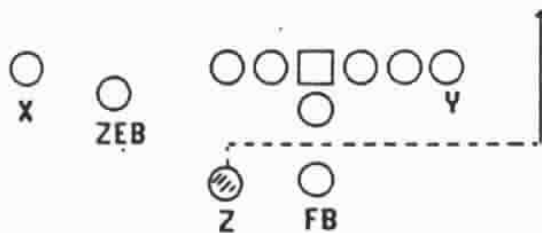

(ZEB) DOUBLE WING RT 'Z' RIGHT

SPLIT-END (X) ALIGNMENTS

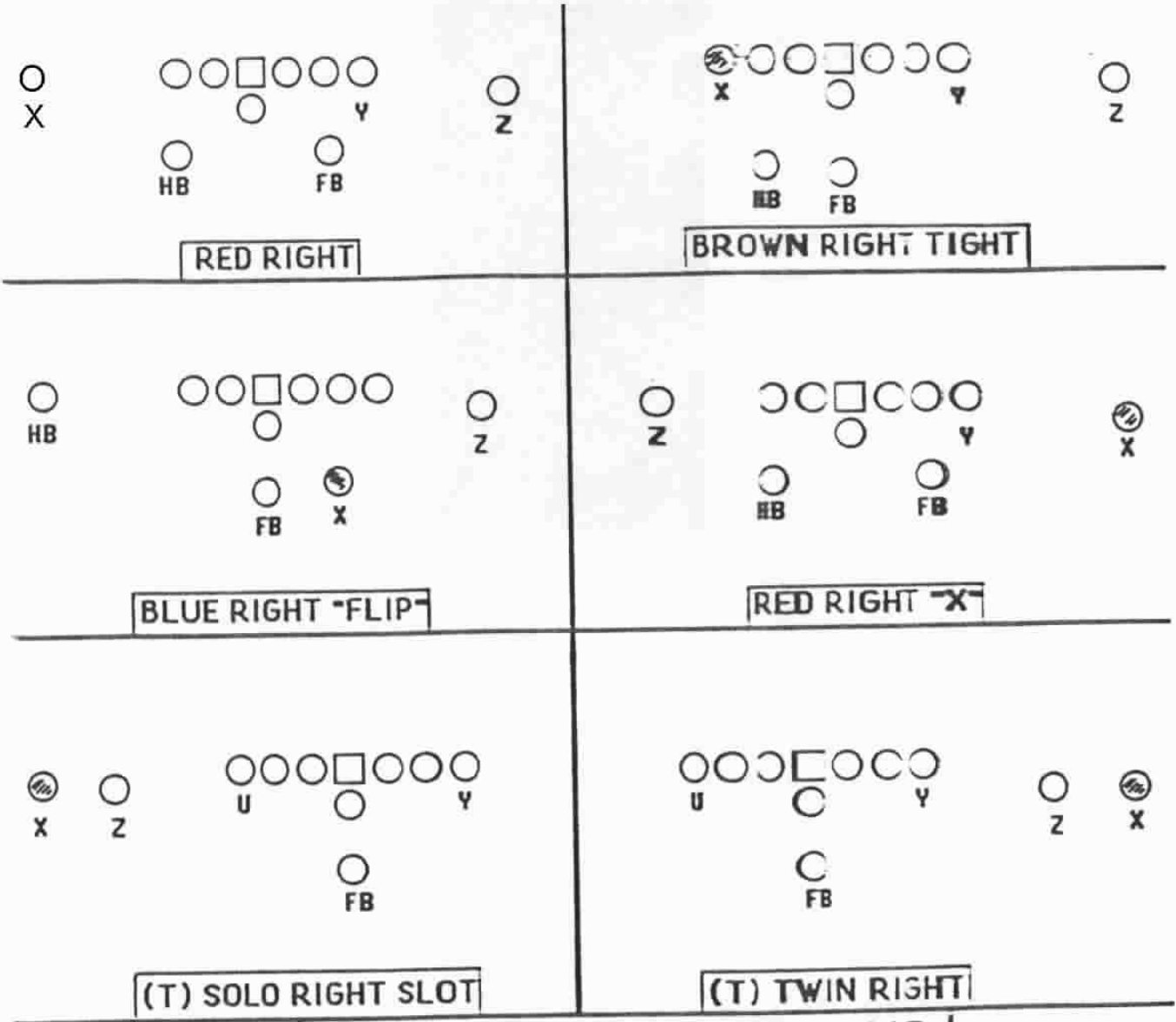

SPLIT-END (X) MOTIONS

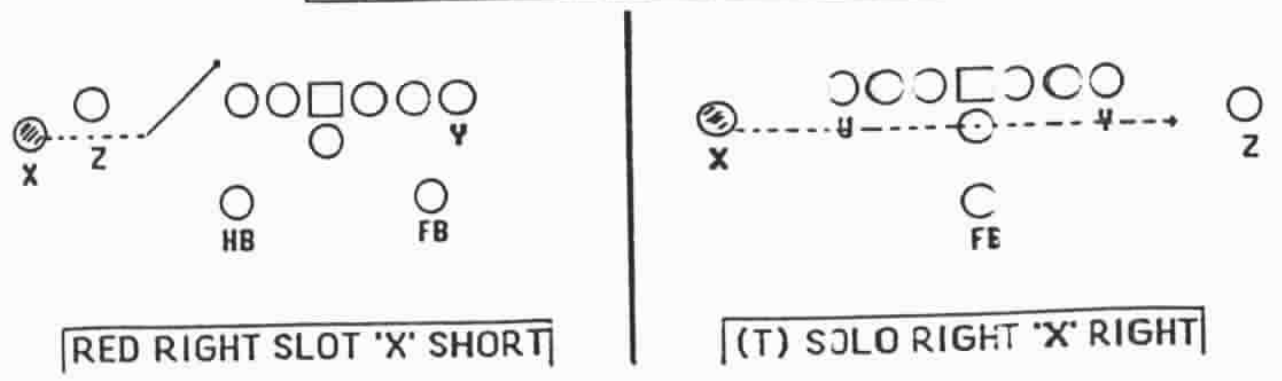

Mini Camp - DAY 1

BASE PASSES:

1. 324-325 THUNDER / OMAHA -- RED
2. 322-323 'Y' STICK -- BROWN SLOT 'A-C' STRONG
-- (T) EAST SLOT 'U' CTR MOTION
3. 22-23 (SCAT) 'Z' IN -- (T) SOLO
-- DOUBLE WING
4. 22-23 (SCAT) TEXAS -- RED
-- DOUBLE WING
-- (ZEB) DOUBLE WING
-- RED (POS. 'Y' SHIFT)
-- RED SLOT
5. 22-23 FB ARROW -- BROWN 'X' 'A-C' STRONG
6. 50-51 'X' SPOT -- BROWN 'X' 'A-C' STRONG
7. 200-300 JET 'Z' SLANT/OMAHA/
THUNDER/SMOKE/SLUGGO -- BROWN 'X' 'A-C' STRONG
8. 2-3 JET 'FLK' DRIVE -- BLUE 'F' SHORT
-- BROWN 'A-C' STRONG

PLAY PASSES:

9. FOX 2-3 'X-Y' HOOK -- BROWN
-- RED
-- GREEN
10. P. 312 D.Q.H. -- GREEN RIGHT FLASH
-- GREEN RIGHT SLOT FLASH
11. P. 312 WK. D.Q.H. -- GREEN LEFT FLASH
-- GREEN LEFT SLOT FLASH
12. P. FB@0 D.Q.H. -- BROWN SLOT 'A-C' STRONG

SCREEN PASSES:

13. 2-3 JET FB SLOW SCREEN STR. -- BLUE 'F' SHORT

RUNS:

1. HB/FB 40-41 -- RED
-- BLUE
2. 18-19 BOB -- RED
3. 16-17 POWER -- RED
4. 68-69 H.O. (SOLID) -- (T) SOLO
-- BLUE
5. 69-68 H.O. (WEAK) -- BROWN
6. 36-37 'F' -- BROWN SLOT 'A-C' STRONG
-- FAR WEST SLOT
7. 92-93 LEAD -- GREEN

RED RIGHT
324 THUNDER/SMOKE

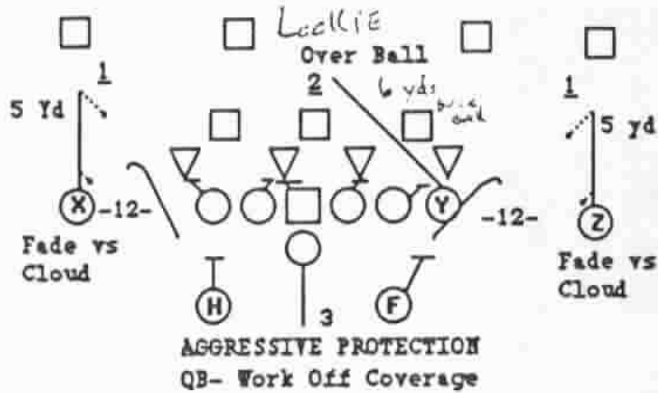

(1)

BASE

BROWN RIGHT SLOT 'A' RIGHT
322 'Y' STICK

(1)

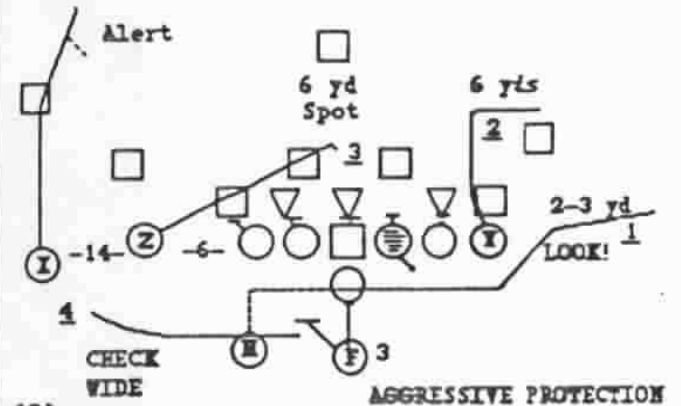

(2)

(T) EAST RIGHT SLOT 'U' COUNTER MOTION
322 'Y' STICK

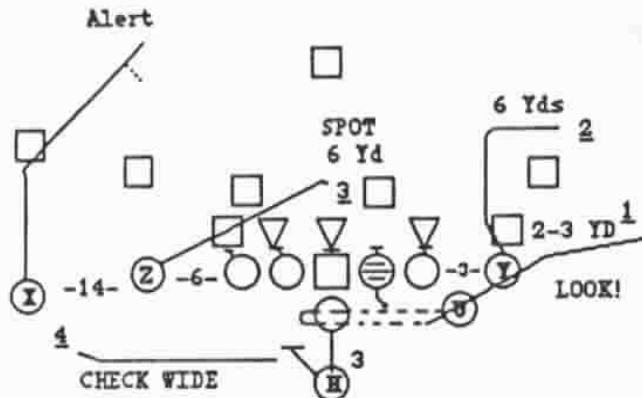

(2A)

(T) SOLO RIGHT
22 'Z' IN
ALERT 'OVER' CALL

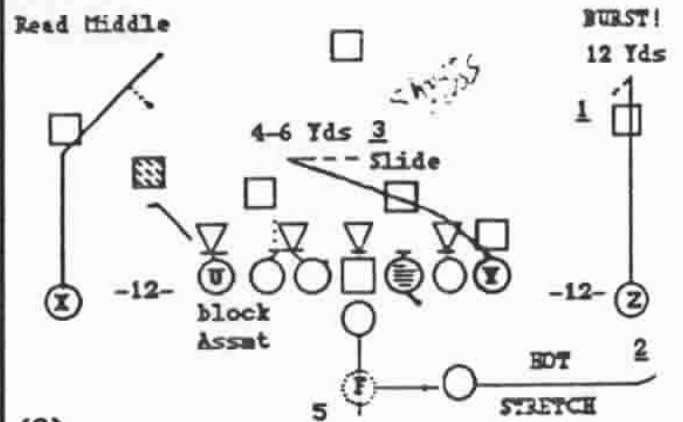

(3)

DOUBLE WING RIGHT
22 SCAT 'Z' IN

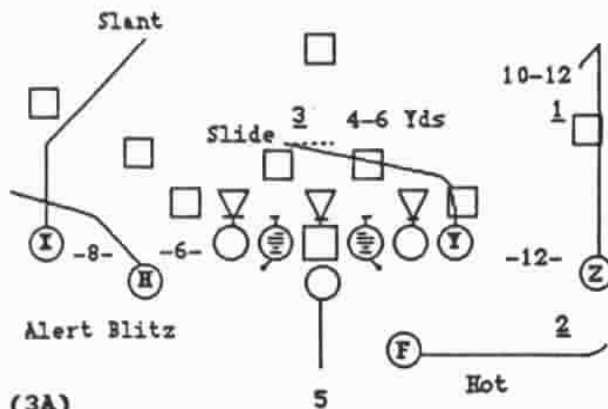

(3A)

RED RIGHT
22 TEXAS

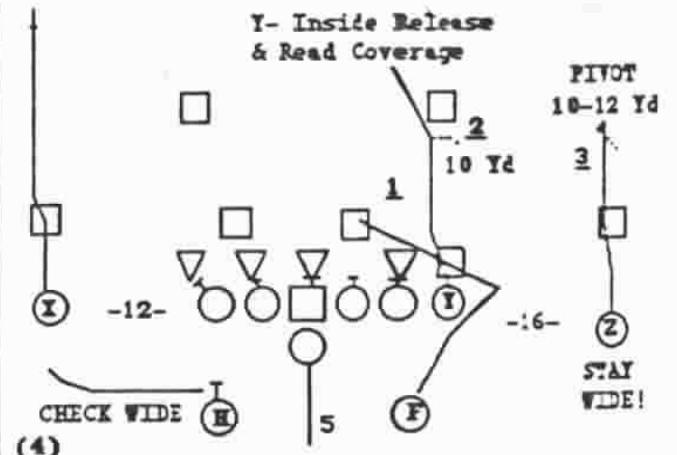

(4)

BROWN RIGHT SLOT 'A' RIGHT
P. FB @ 0 DOUBLE QUICK HITCH

SCREENS

BLUE RIGHT "F" SHORT
2 JET FB SLOW SCREEN RIGHT (4)

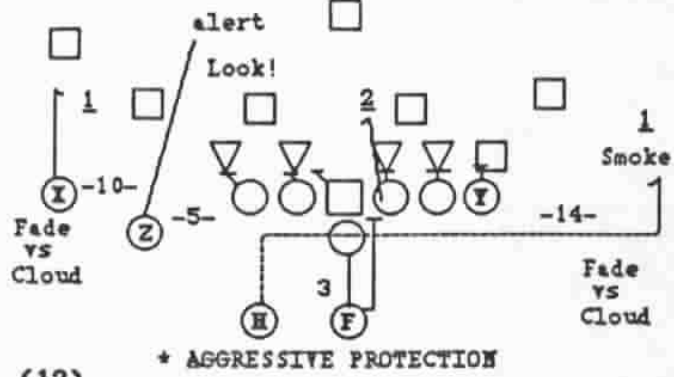

(12)

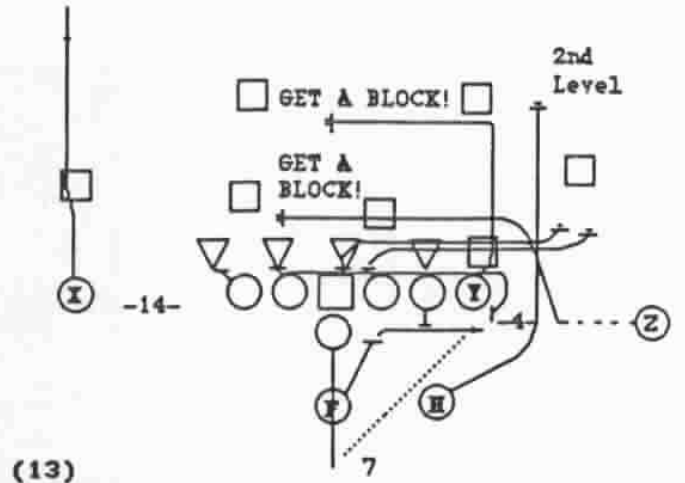

(13)

FB 40-41

49

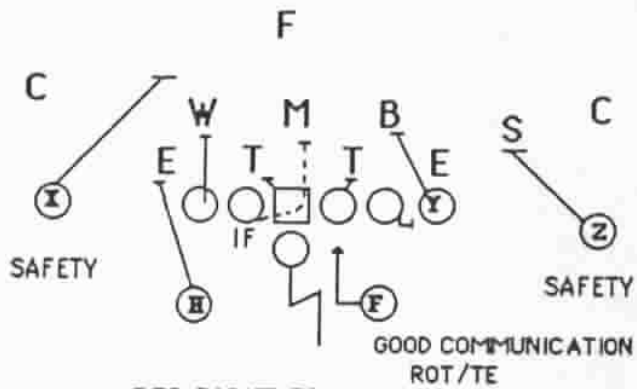

RED RIGHT FB 40

43

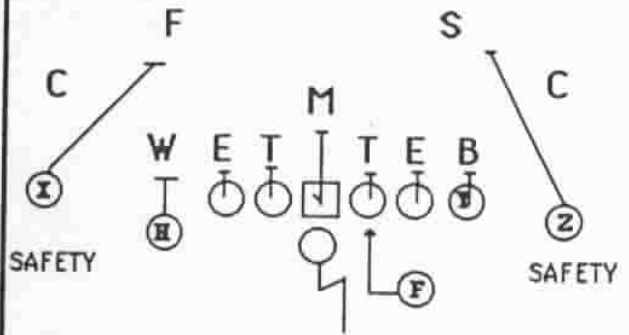

DOUBLE WING RIGHT FB 40

25 (35)

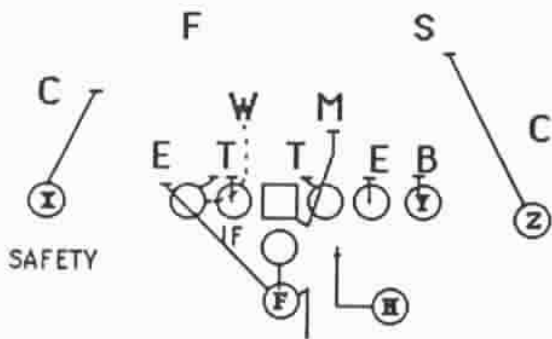

BLUE RIGHT HB 40

57 (37)



RED RIGHT FB 40

59

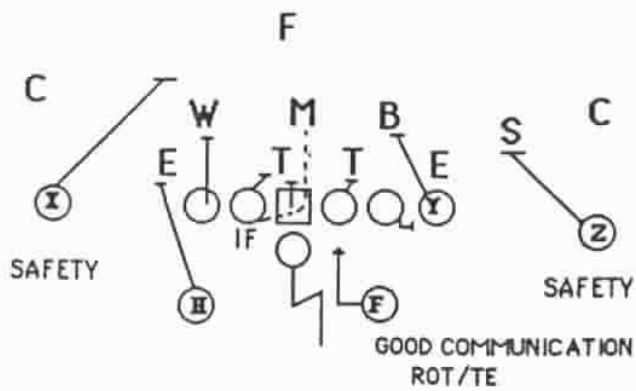

RED RIGHT FB 40

42

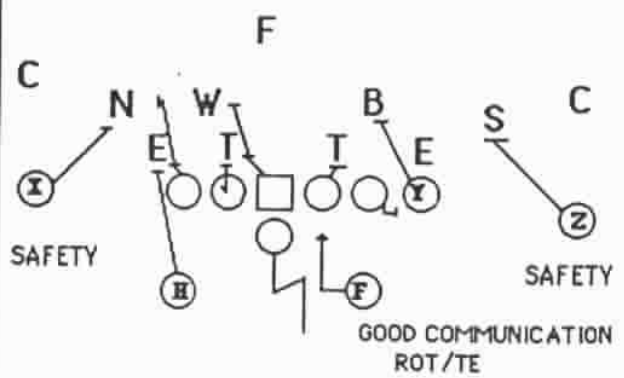

RED RIGHT FB 40

18-19 BOB

49

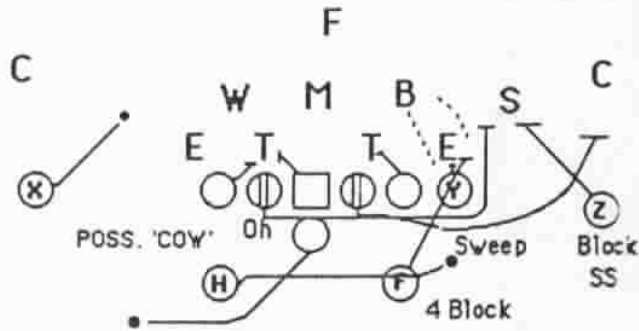

RED RT 18 BOB

43

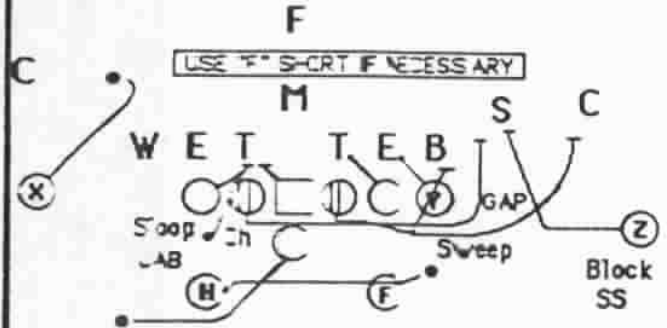

RED RT 18 BOB

25 (35)

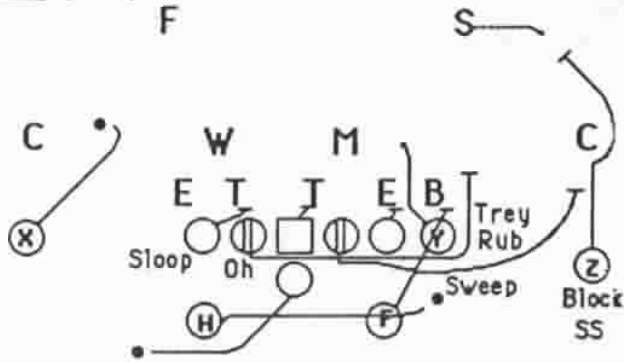

RED RT 18 BOB

57 (37)

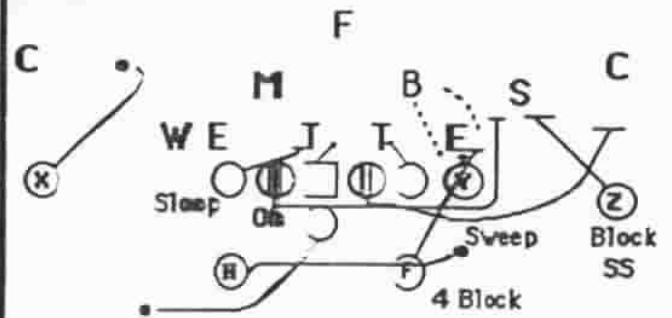

RED RT 18 BOB

59

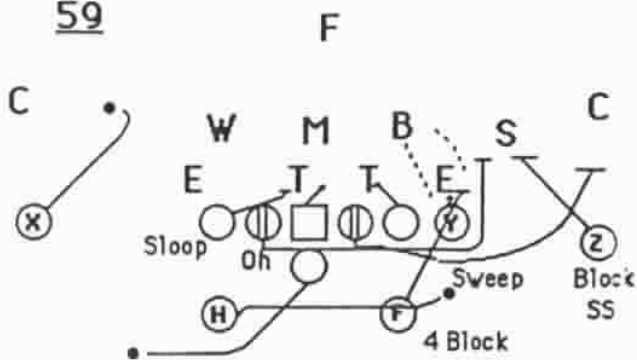

RED RT 18 BOB

42

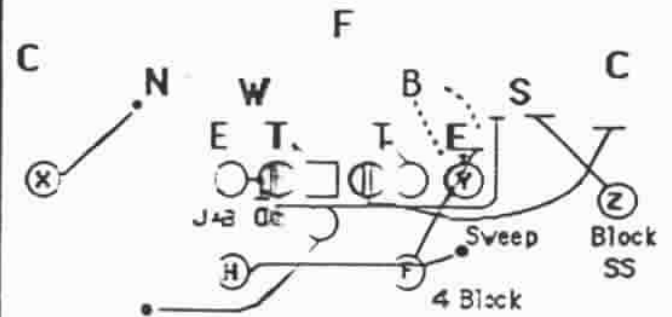

RED RT 18 BOB

16-17 POWER

49

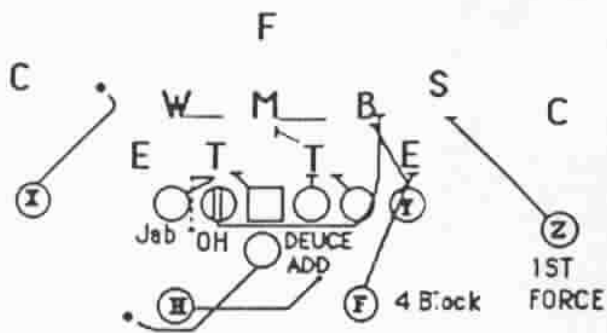

RED RT 16 POWER

43

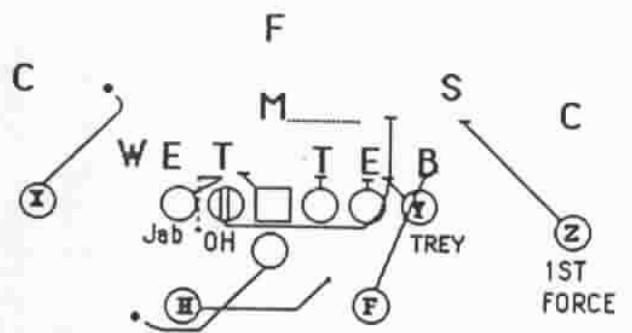

RED RT 16 POWER

25 (35)

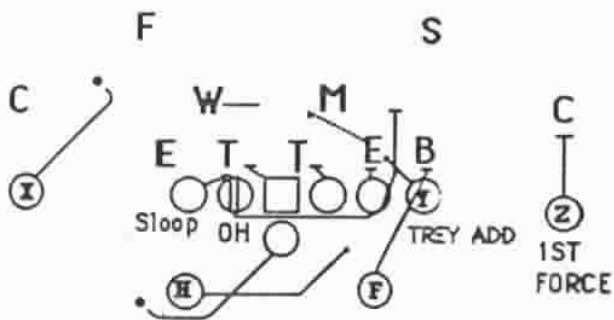

RED RT 16 POWER

57 (37)

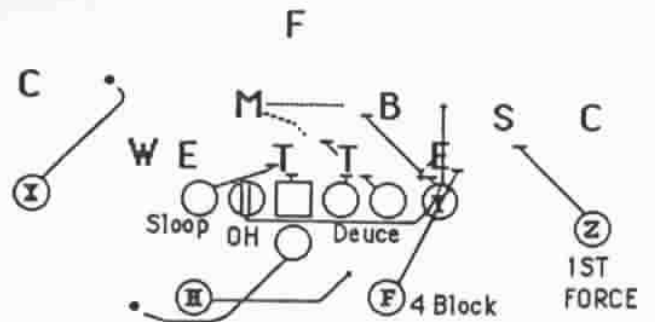

RED RT 16 POWER

59

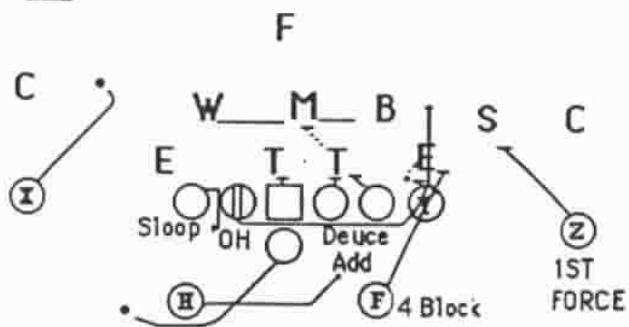

RED RT 16 POWER

42

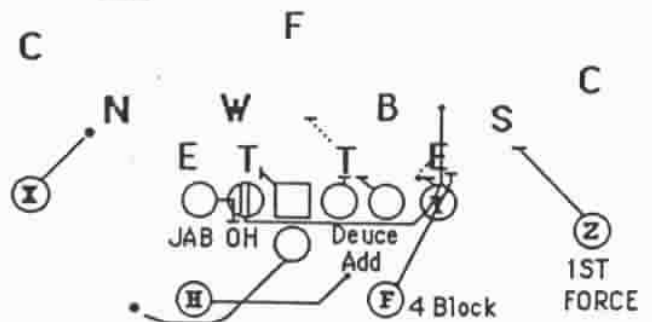

RED RT 16 POWER

68-69 HO SOLID

34

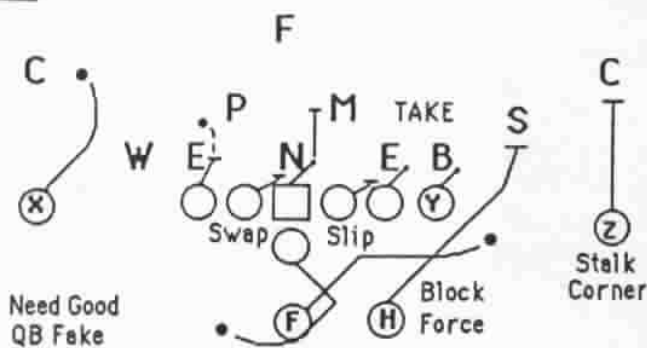

BLUE RIGHT 68 HO SOLID

43

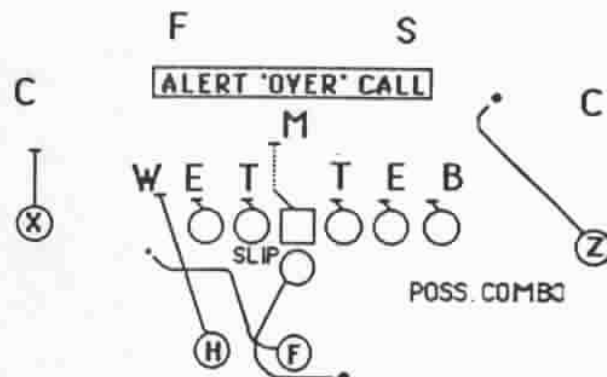

BROWN RIGHT 69 HO (WK)

25



(T) SOLO RIGHT 68 'HO'

57 (37)

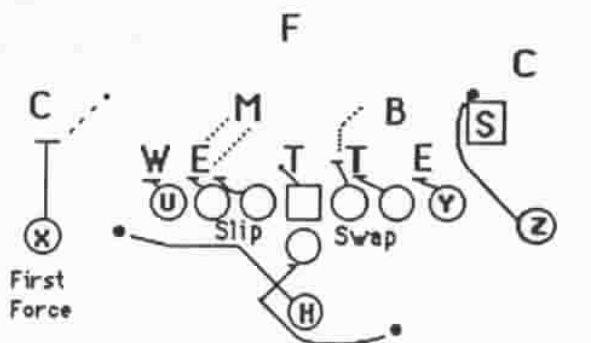

(T) SOLO RIGHT 68 HO ('OVER' CALL)

59

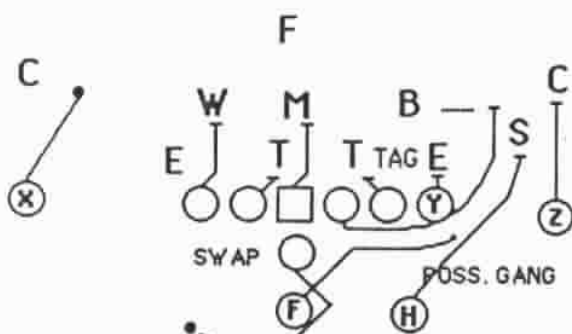

BLUE RIGHT 68 'HO' SOLID

42

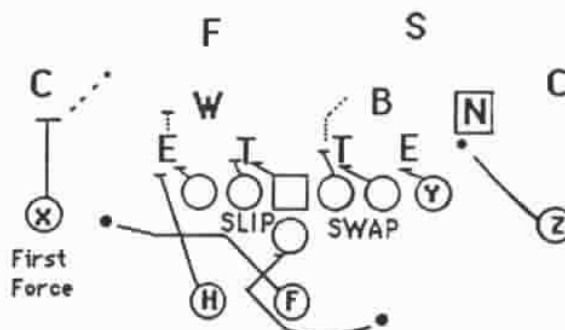

BROWN RIGHT 68 HO ('OVER' CALL)

68-69 HO

49

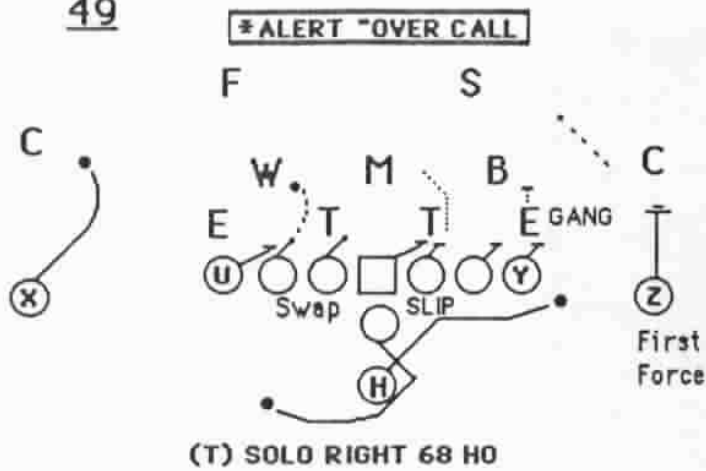

43

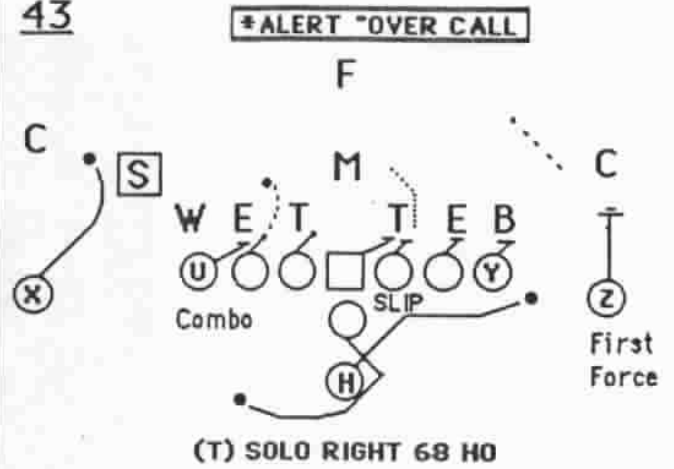

25 (35)



57 (37)

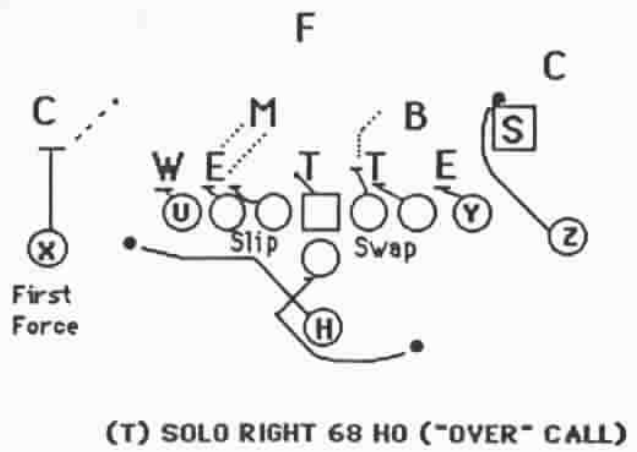

59

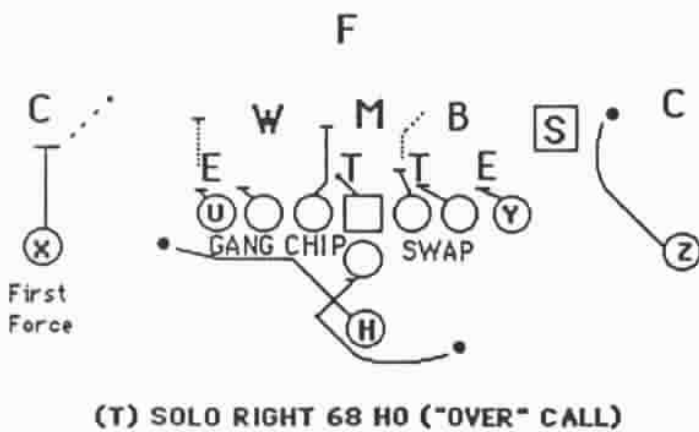

42



92-93 LEAD

49 F S

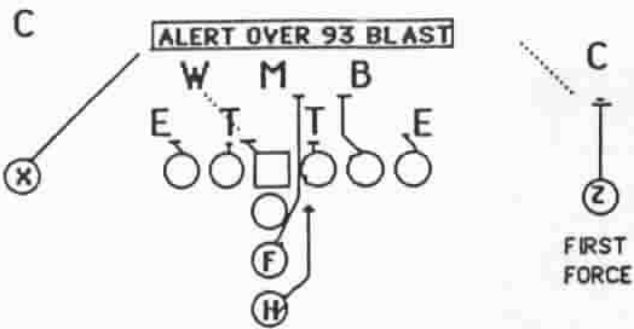

GREEN RIGHT 92 LEAD

25

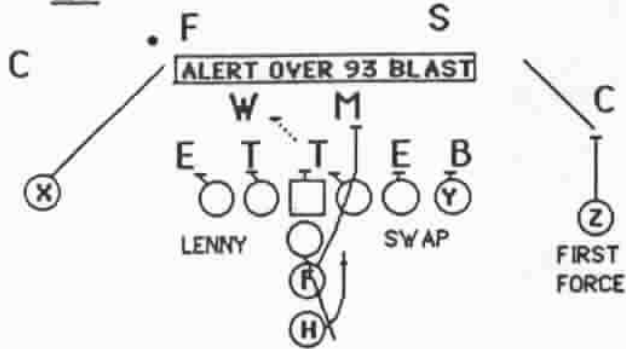

GREEN RIGHT 92 LEAD

57

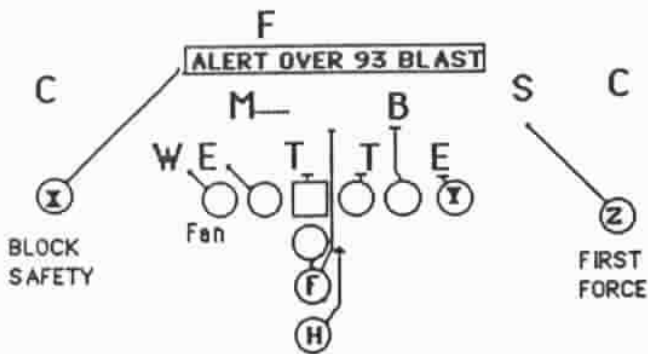

59

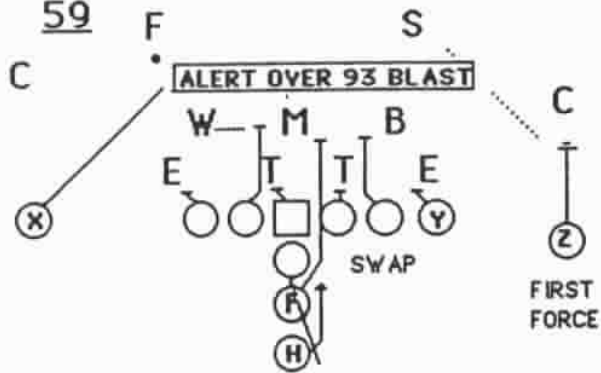

GREEN RIGHT 92 LEAD

Mini Camp - DAY 2

BASE PASSES:

- | | |
|-------------------------------|-------------------------|
| 1. 324-325 SMOKE / TRAIN | -- RED |
| 2. 22-23 'Y/E' CROSS FB FAN | -- RED (POS. 'Y' SHIFT) |
| | -- (E) RED |
| 3. 22-23 DBL SEAM POST | -- (T) SOLO 'U' STRONG |
| 4. 22-23 SCAT HANK | -- DOUBLE WING |
| 5. 22-23 SCAT TEXAS 'Y' CROSS | -- DOUBLE WING |
| | -- (ZEB) DOUBLE WING |
| 6. 22-23 'X' SHALLOW CROSS | -- BROWN 'A-C' STRONG |
| 7. 24-25 DBL CB/DIG/GO | -- RED |
| 8. 72-73 'X' SHALLOW CROSS | -- CHANGE 'A-C' WEAK |
| 9. 2-3 JET ALL GO (FK. FB40) | -- FB WEST SLOT |
| 10. 2-3 JET 'X' DRIVE | -- BROWN SLOT OPEN |

PLAY PASSES:

- | | |
|------------------|----------------|
| 11. FOX 2 D.S.O. | -- BROWN RIGHT |
| 12. H2-3 D.S.O. | -- GREEN FLASH |

MOVEMENT PASSES:

- | | |
|-------------------------------|-----------------------|
| 13. FK. 69 QB KEEP PASS RIGHT | -- (T) SOLO LEFT |
| | -- (T) SOLO LEFT SLOT |

SCREENS:

- | | |
|----------------------------------|--------|
| 14. 22-23 TEXAS HB SLOW SCR. WK. | -- RED |
|----------------------------------|--------|

RUNS:

- | | |
|---------------------|----------------------|
| 1. FOX 2-3 RUN | -- BROWN |
| | -- RED |
| | -- GREEN |
| 2. FOX 3-2 WEAK | -- RED (SLOT) |
| | -- BLUE ('Y' MOTION) |
| | -- GREEN |
| 3. 98-99 H.O. SOLID | -- GREEN |
| 4. 93-92 BLAST | -- GREEN |
| 5. 19-18 'W' | -- RED |
| | -- (E) RED (CHANGE) |

RED RIGHT
324 OMAHA

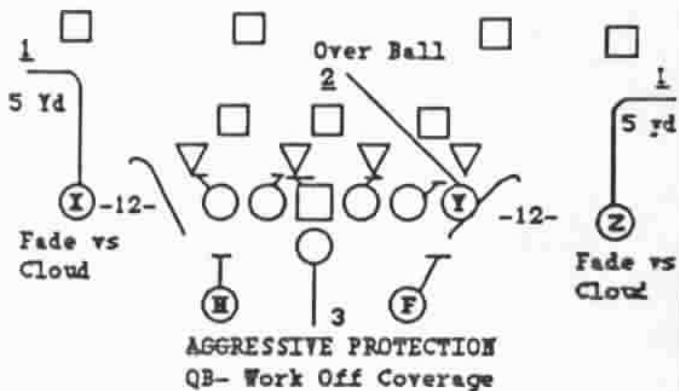

(1)

RED RIGHT
324 TRAIN

(5)

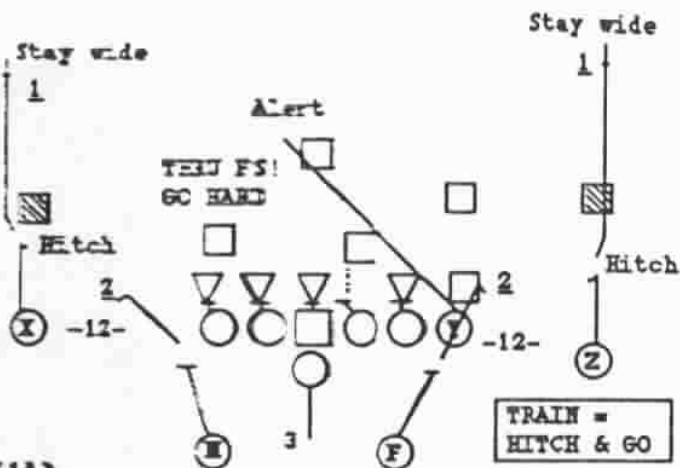

(1A)

'Y' SHIFT TO RED RIGHT
22 'Y' CROSS FB FAN

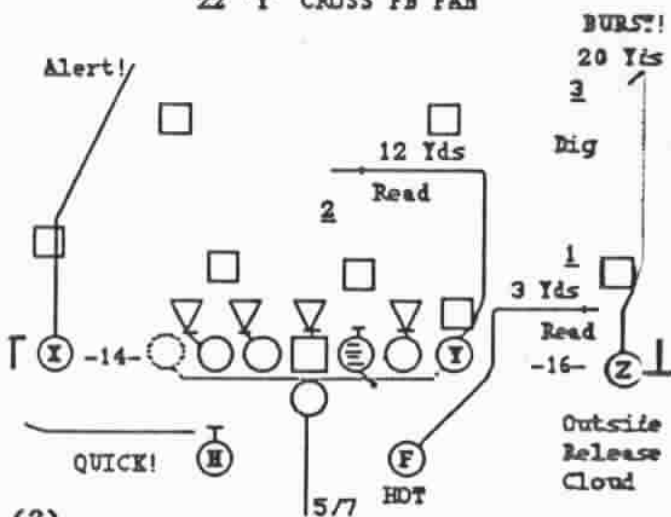

(2)

(E) RED RIGHT
22 'E' CROSS FB FAN

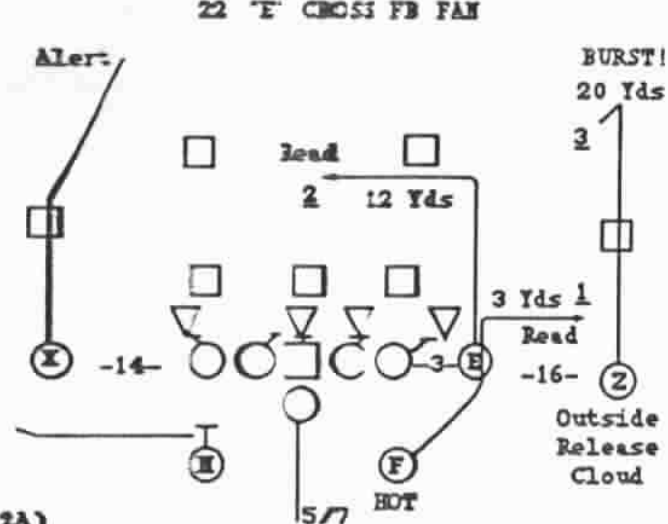

(2A)

(T) SOLO RIGHT 'U' RIGHT
22 DOUBLE SEAM POST

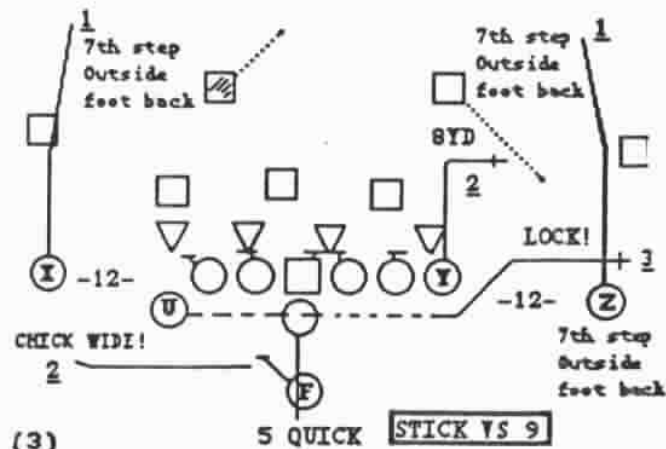

(3)

DOUBLE WING RIGHT
22 SAT BANK

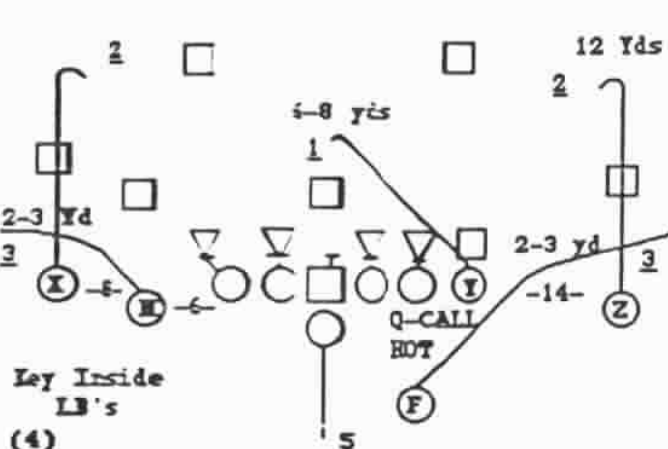

(4)

DOUBLE WING RIGHT
22 SCAT TEXAS 'Y' CROSS

BASE

(ZB) DOUBLE WING RIGHT
22 SCAT TEXAS 'Y' CROSS

(6)

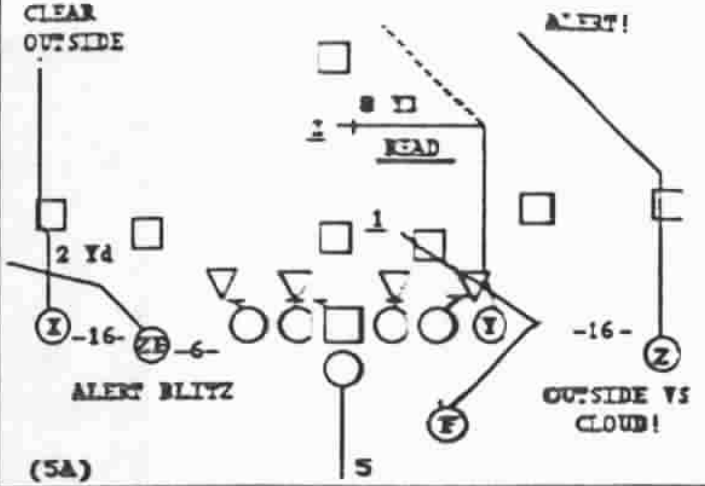
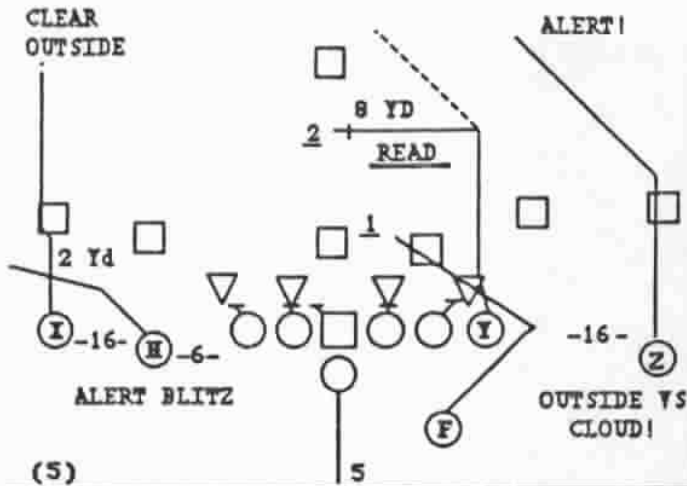

BROWN RIGHT 'A' RIGHT
22 'X' SHALLOW CROSS

BEE RIGHT
24 DOUBLE CB/DIG/GO

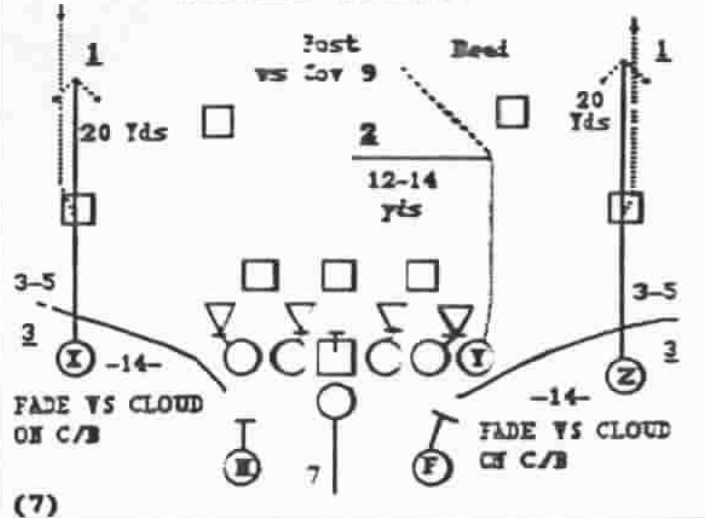
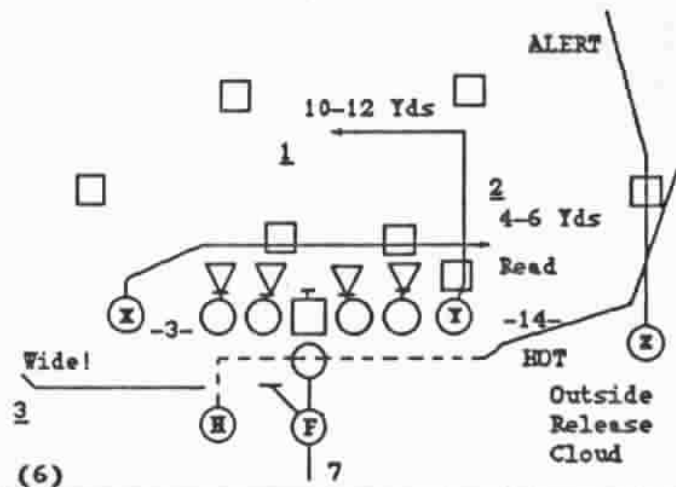

CHANGE RIGHT 'C' LEFT
72 'X' SHALLOW CROSS

F3 WEST RIGHT SLOT
2 JET AL GO (FX FB40)

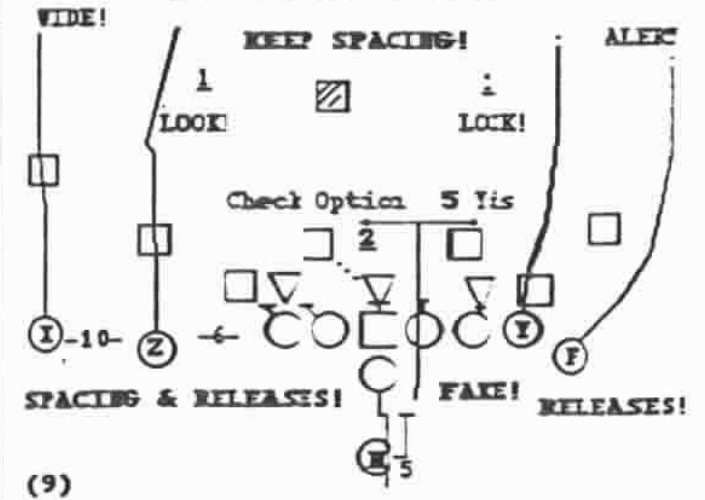
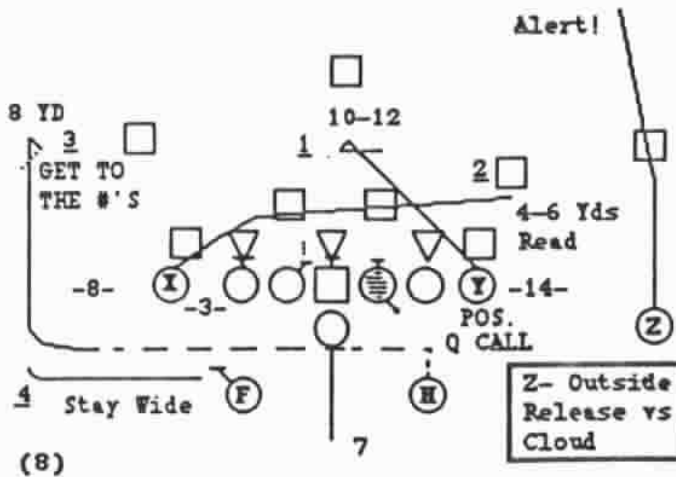

**BROWN RIGHT SLOT OPEN
3 JET "X" DRIVE**

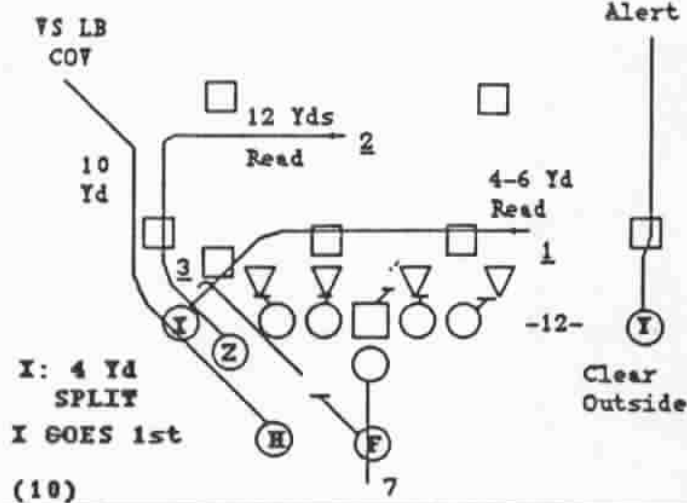

PLAY PASS

**BROWN RIGHT
FOI 2 DOUBLE SQUARE OUT**

(7)

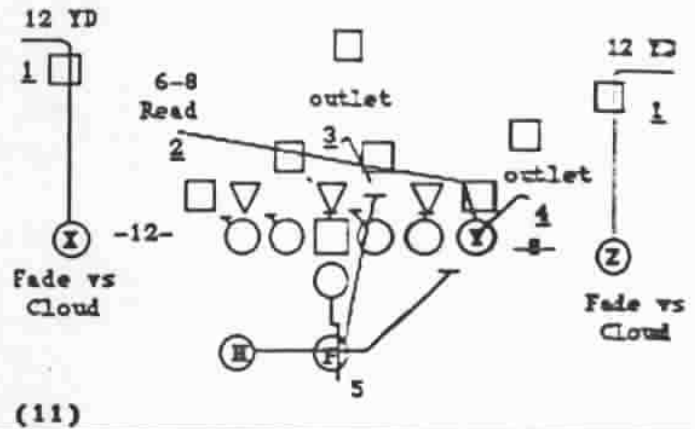

**GREEN RIGHT FLASH
H2 DOUBLE SQUARE OUT**

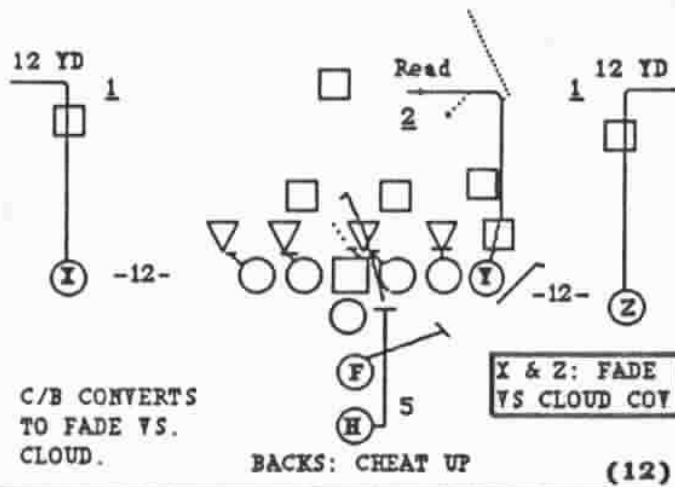

MOVEMENT

**(T) SOLO LEFT
FAKE 69 QB KEEP PASS RIGHT
(POSSIBLE 'OVER')**

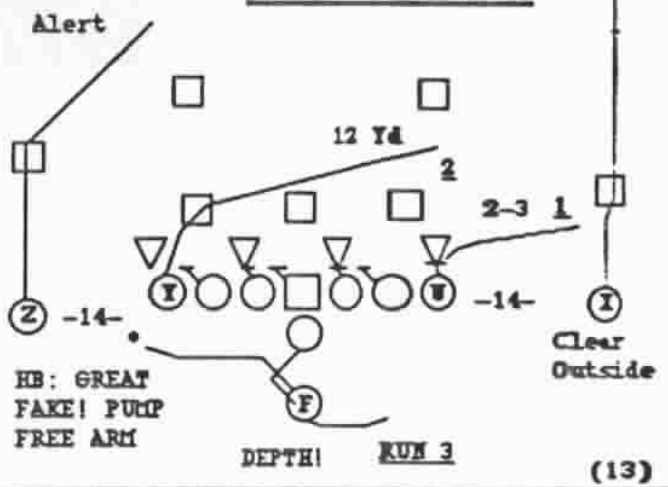

**(T) SOLO LEFT SLOT
FAKE 69 QB KEEP PASS RIGHT**

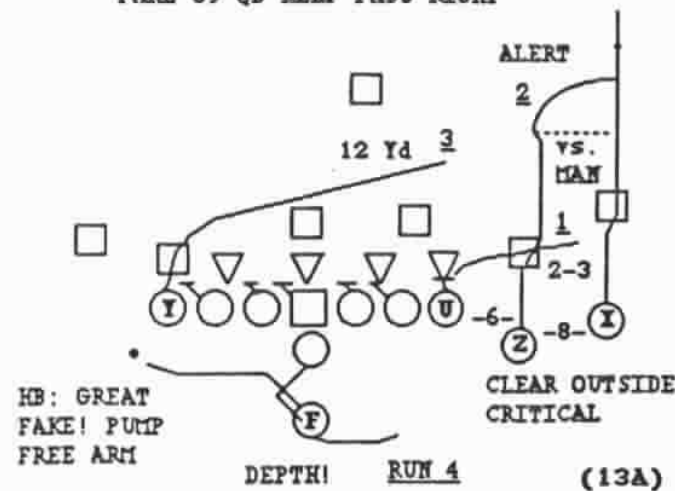

SCREENS

**RED RIGHT
22 TEXAS HB SLOW SCREEN LEFT**

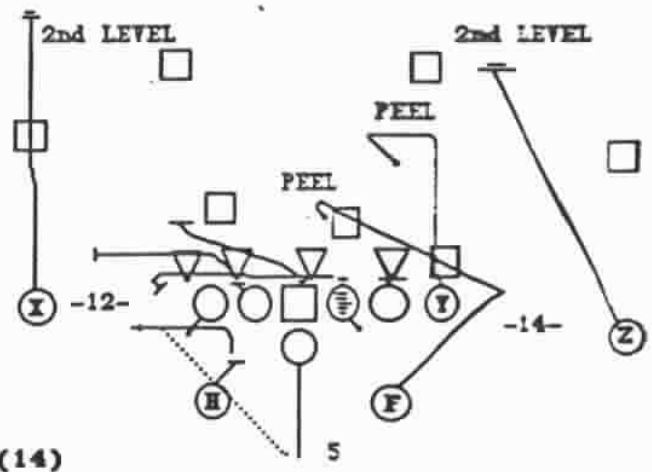

FOX 2-3 RUN

49

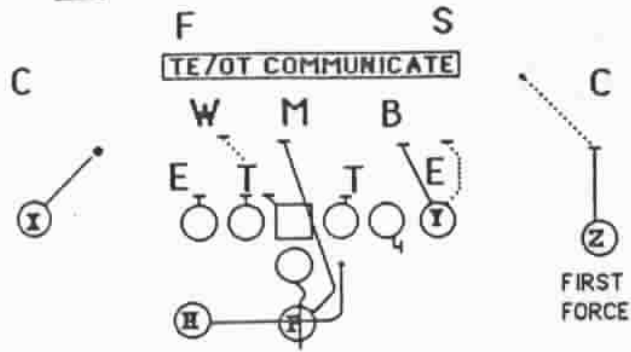

BROWN RIGHT FOX 2 RUN

43

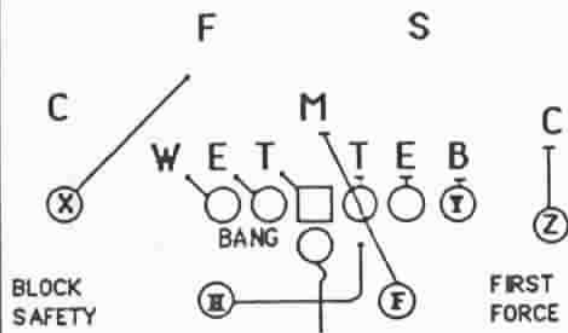

RED RIGHT FOX 2 RUN

25 (35)

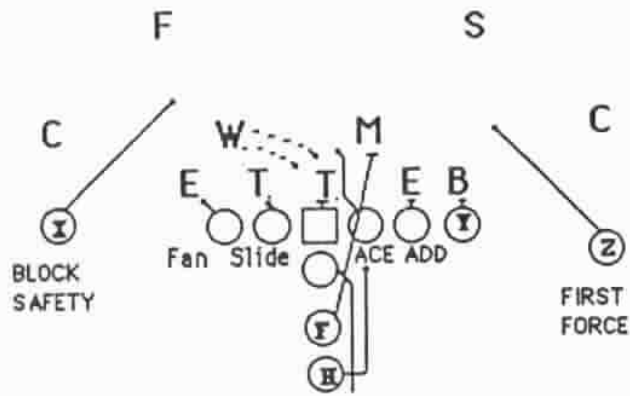

GREEN RIGHT FOX 2 RUN

57 (37)

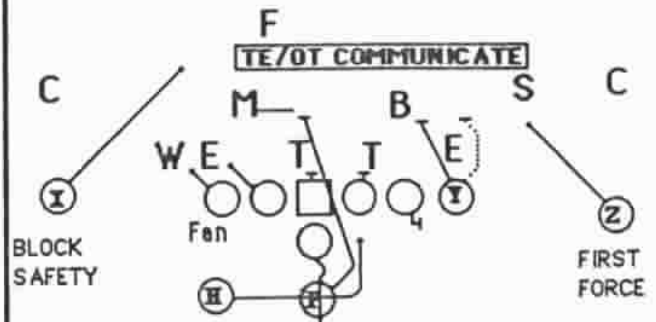

BROWN RIGHT FOX 2 RUN

59

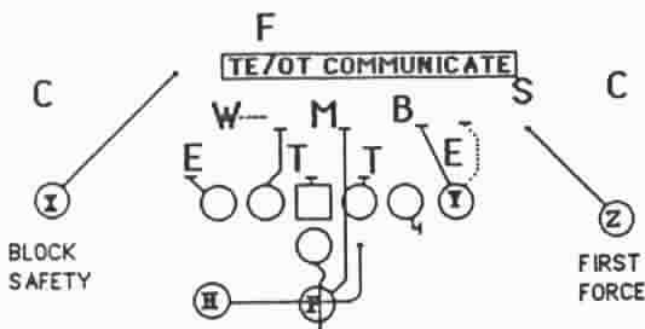

BROWN RIGHT FOX 2 RUN

42

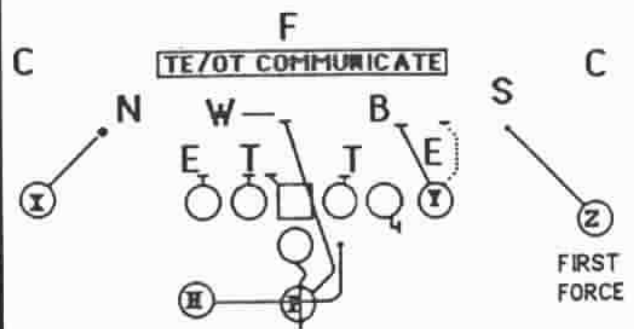

BROWN RIGHT FOX 2 RUN

FOX 3-2 WEAK

49

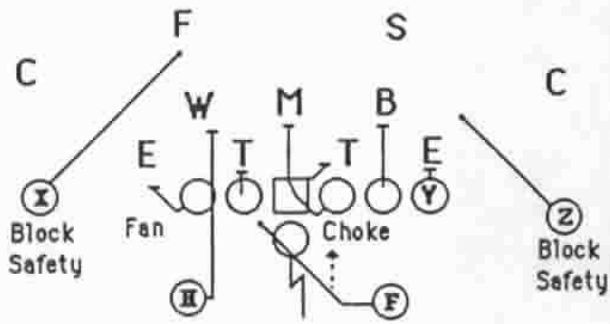

RED RIGHT FOX 3 WEAK

43

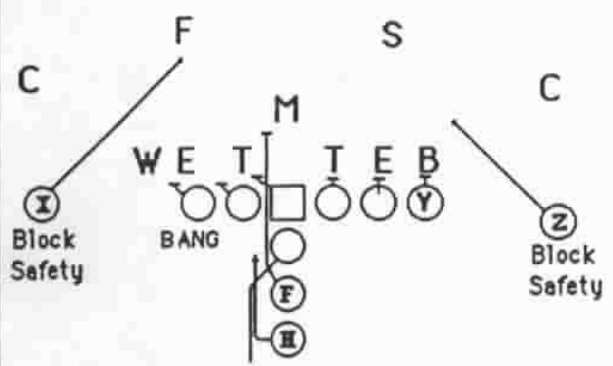

GREEN RIGHT FOX 3 WEAK

25 (35)

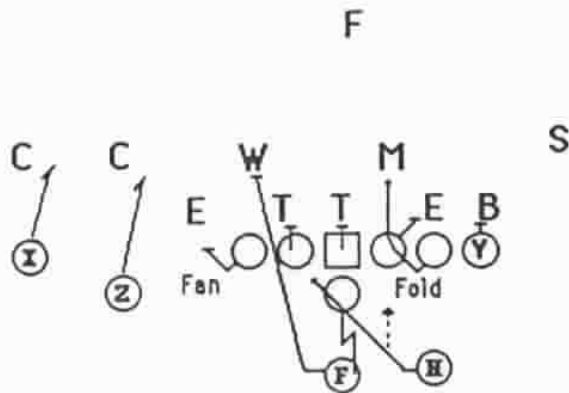

BLUE RIGHT FOX 3 WEAK

57 (37)

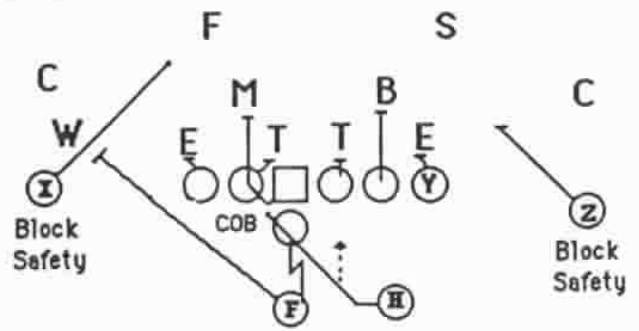

BLUE RIGHT FOX 3 WEAK

59

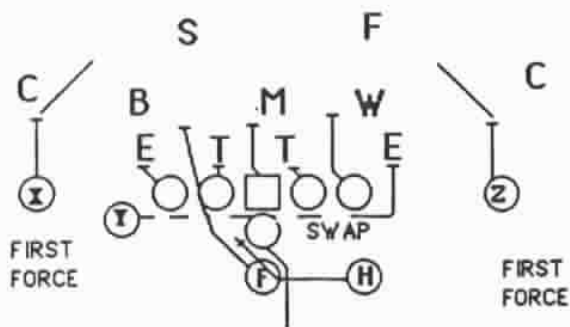

BLUE RIGHT 'Y' MOTION FOX 3 WK

42

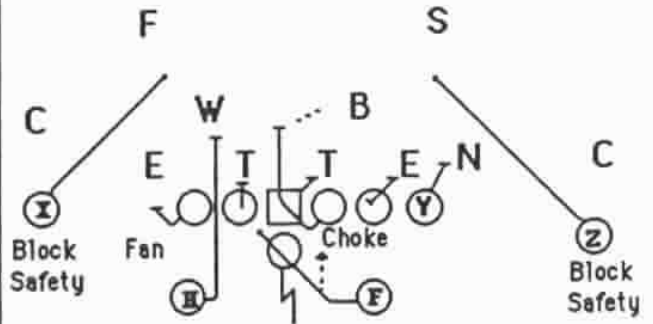

RED RIGHT FOX 3 WEAK

98-99 'H0' SOLID

49

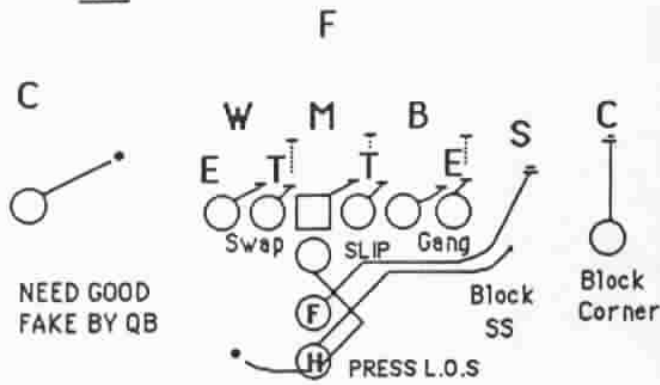

GREEN RIGHT 98 'H0' SOLID

43

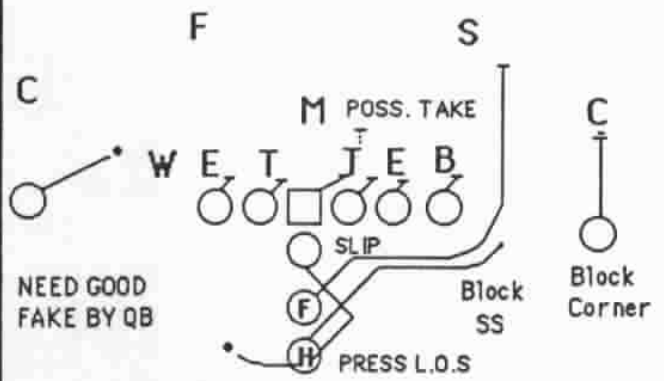

GREEN RIGHT 98 'H0' SOLID

25 (35)

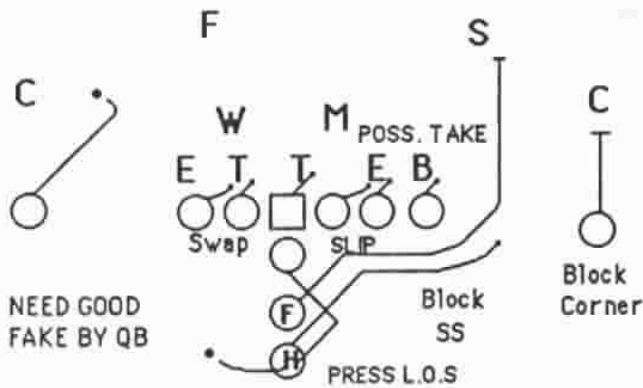

GREEN RIGHT 98 'H0' SOLID

57 (37)

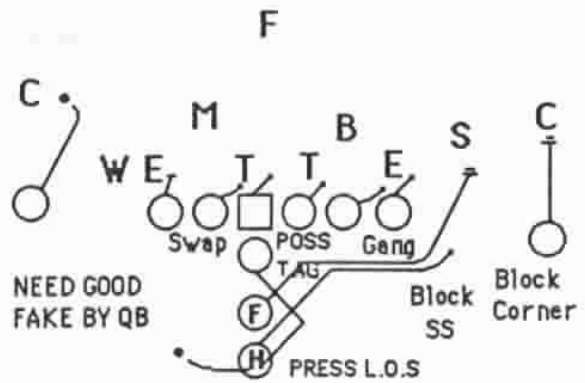

GREEN RIGHT 98 'H0' SOLID

59

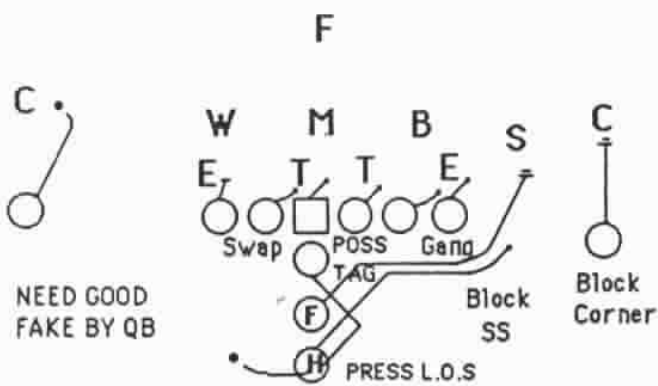

GREEN RIGHT 98 'H0' SOLID

42

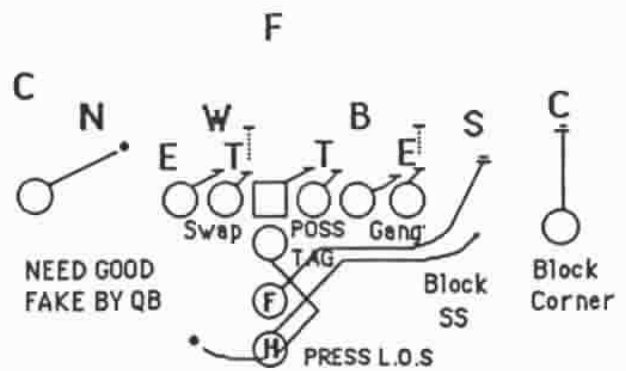

GREEN RIGHT 98 'H0' SOLID

93-92 BLAST

49

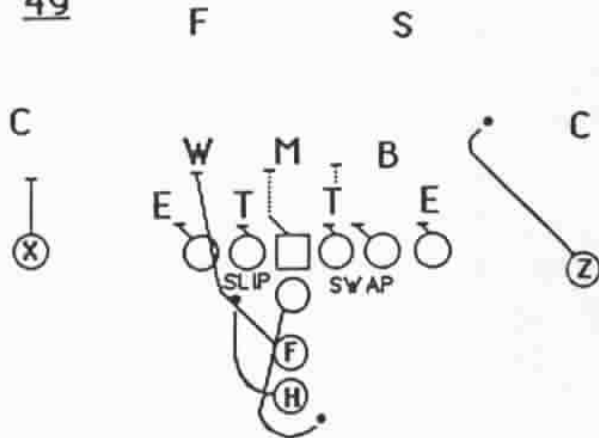

GREEN RIGHT 93 BLAST

43

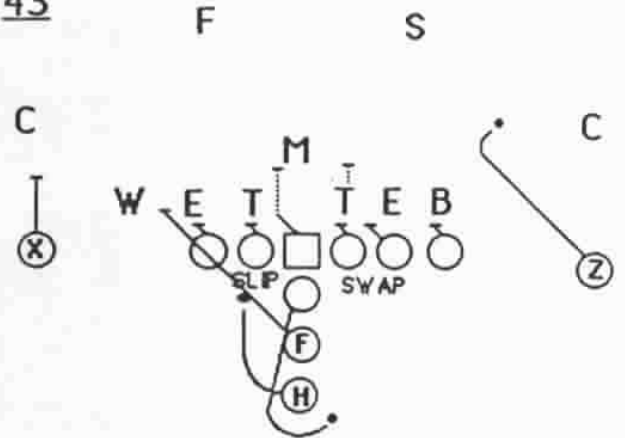

GREEN RIGHT 93 BLAST

25 (35)

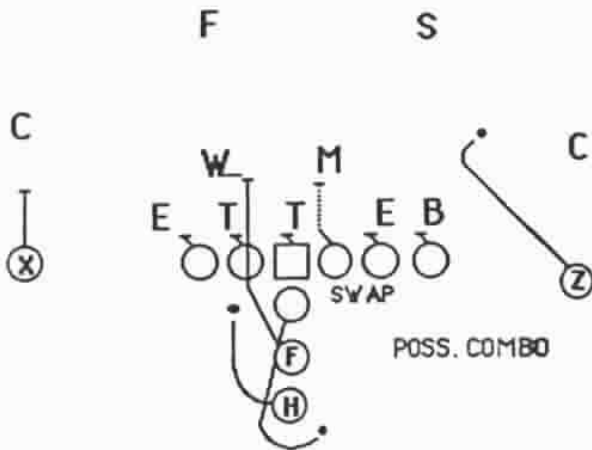

GREEN RIGHT 93 BLAST

57 (37)

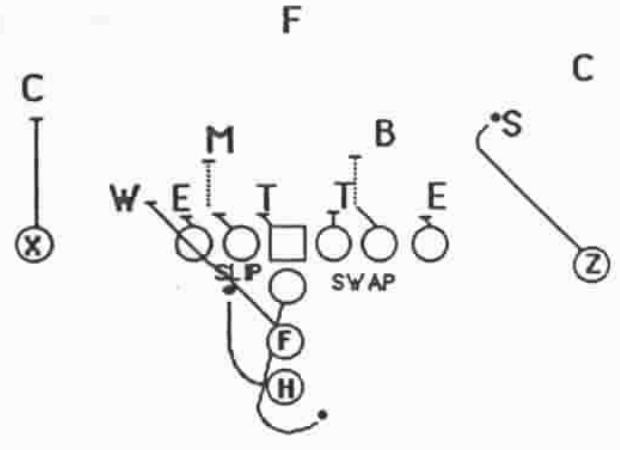

GREEN RIGHT 93 BLAST

59

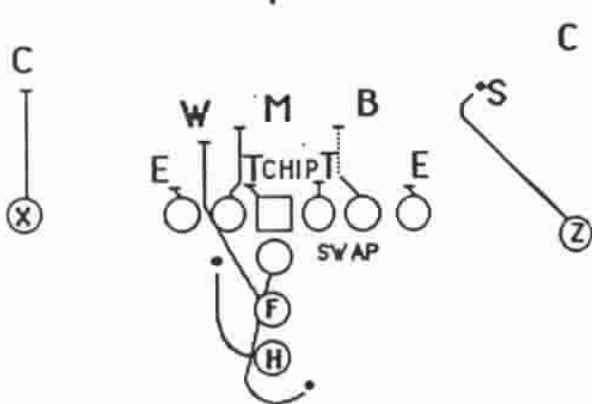

GREEN RIGHT 93 BLAST

42

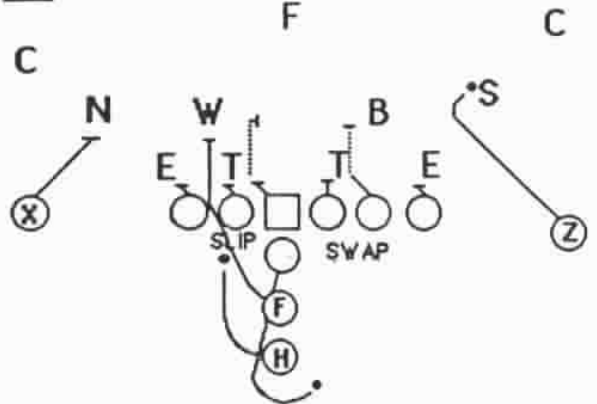

GREEN RIGHT 93 BLAST

19-18 'W'

49

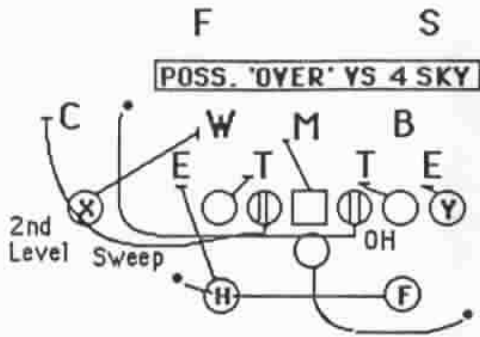

RED RIGHT 19 'W'

43

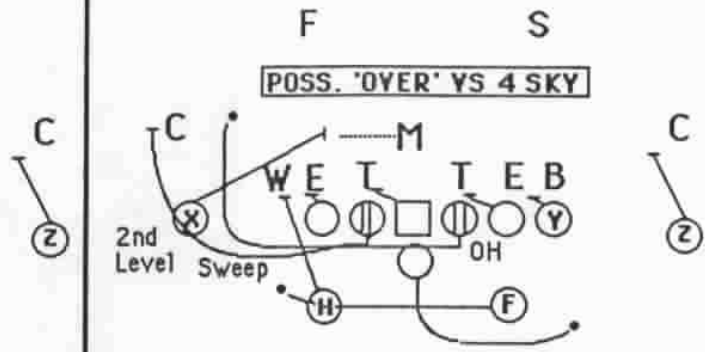

RED RIGHT 19 'W'

25 (35)

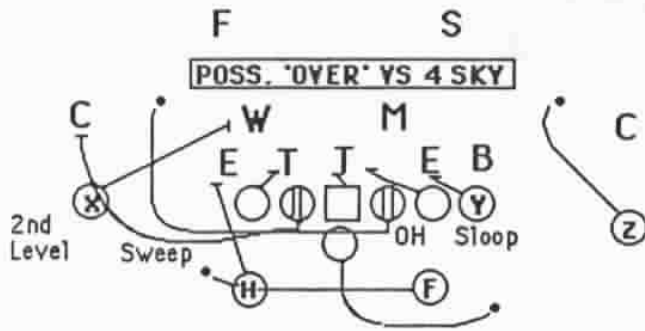

RED RIGHT 19 'W'

57 (37)

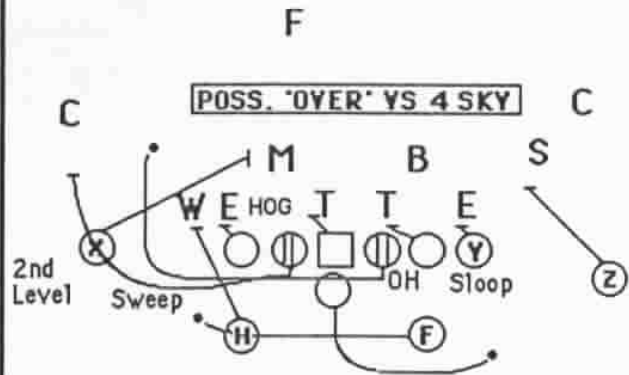

RED RIGHT 19 'W'

59

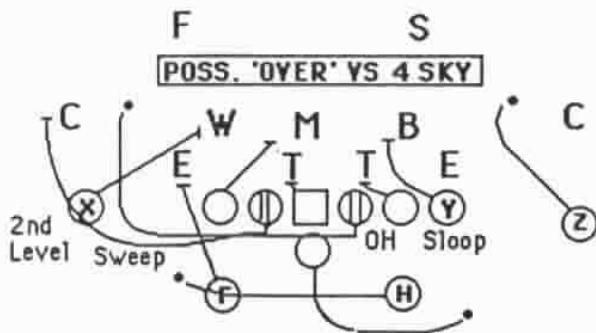

(E) CHANGE RIGHT 19 'W'

42

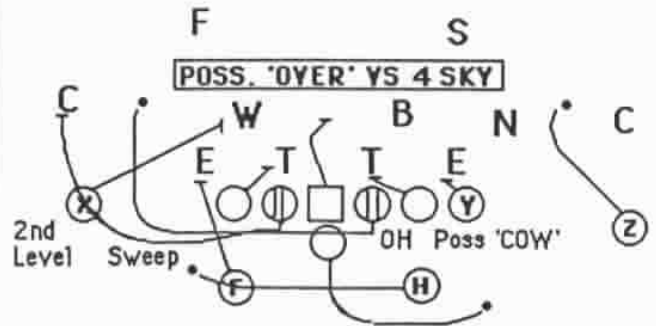

(E) CHANGE RIGHT 19 'W'

Mini Camp - DAY 3

BASE PASSES:

1. 322-323 (SCAT) 'Y' STICK NOD -- RED SLOT 'A-C' STRONG
-- (T) EAST SLOT 'U' CTR MOTION
2. 22-23 DBL STUTTER GO -- RED
3. 200-300 JET 'X' SLANT/OMAHA/
THUNDER/SMOKE/SLUGGO -- (T) EAST 'F' SHORT
4. 3 JET 'FLK' ARROW HB QUICK -- BLUE 'F' SHORT

MOVEMENT PASSES:

5. SPRINT RIGHT OPTION -- RED LEFT SLOT
6. FK. 19 QB KEEP RT. FB SLIDE -- RED LEFT
7. P. 97 SOLID SEATTLE -- (T) SOLO LEFT

SCREENS:

8. SPRINT RIGHT FB SLOW SCR LT. -- RED LEFT SLOT

NICKEL PASSES:

9. 22-23 SCAT 'E' OPTION -- (E) DOUBLE WING
10. 200-300 JET LION / SLUGGO -- (EAG) SPREAD
11. 2-3 JET SEATTLE -- (ZEB) DBL WING 'ZEB' STRONG
12. 2-3 JET 'ZEB' DRIVE 'Z' POST -- (ZEB) TRIPS
13. 2-3 JET WINSTON 'E' CROSS -- (EAG) SPREAD
14. 2-3 JET DBL ARROW 'EAG' CROSS -- (EAG) SPREAD
15. 2-3 JET ALL GO (FK FB40) -- (EAG) SPREAD
16. 2-3 JET ALL GO SPECIAL -- (ZEB) TRIPS
(FK FB40)

NICKEL RUNS:

1. 15-14 DRAW -- (ZEB) DOUBLE WING
-- (ZEB) TRIPS
2. FB 40-41 (STR/WK) -- (ZEB) DOUBLE WING
-- (EAG) SPREAD
3. 66-67 SLANT -- (ZEB) DBL WING ('Alert Over')
4. 66-67 'T' -- (ZEB) DOUBLE WING
5. 60-61 TRAP / 30-31 TRAP -- (ZEB) DOUBLE WING
-- (EAG) SPREAD
6. 68-69 H.O. (SOLID) -- (ZEB) TRIPS ('X')
-- (EAG) SPREAD

RED RIGHT SLOT "A" RIGHT
322 SCAT "Y" STICK MOD

BASE

(T) EAST RIGHT SLOT 'U' CTR MOTION (8)
322 'Y' STICK MOD

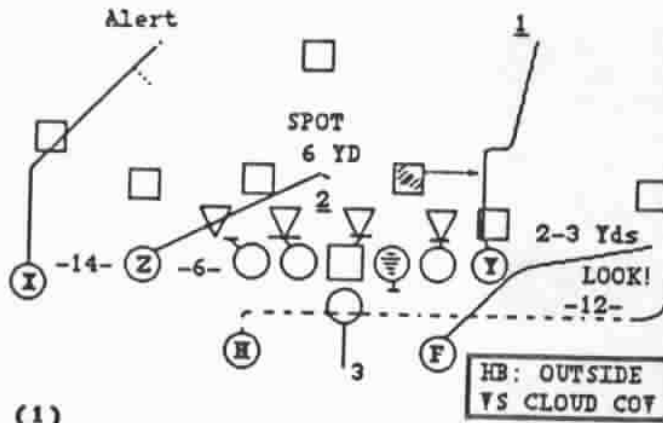

(1)

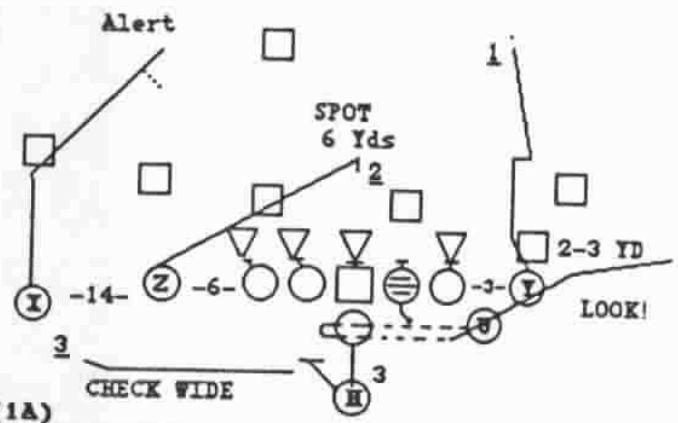

(1A)

RED RIGHT
22 DOUBLE STUTTER GO

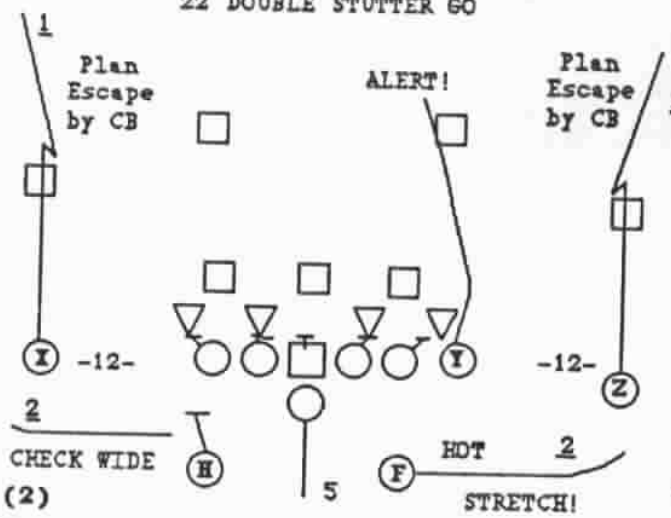

(2)

(T) EAST RIGHT 'F' SHORT
200 JET 'X' SLANT/OM/TH/SH/SLUGGO

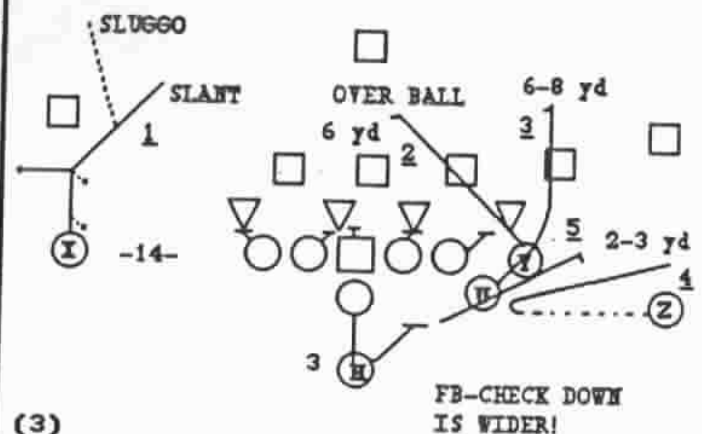

(3)

BLUE RIGHT "F" SHORT
3 JET FLANKER ARROW HB QUICK

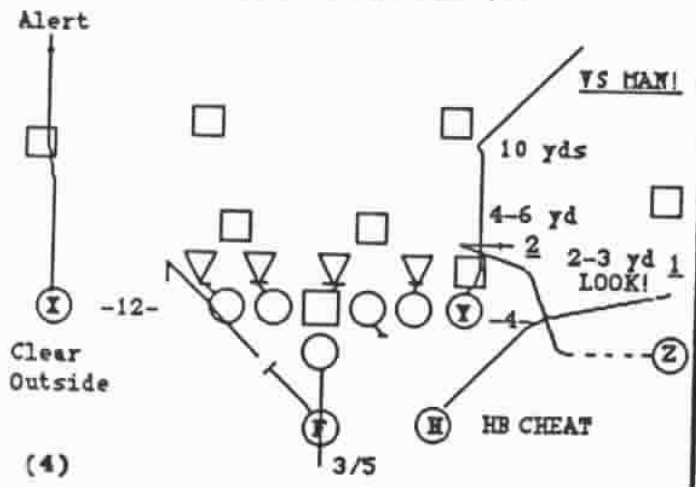

(4)

MOVEMENT

RED LEFT SLOT
SPRINT RIGHT OPTION

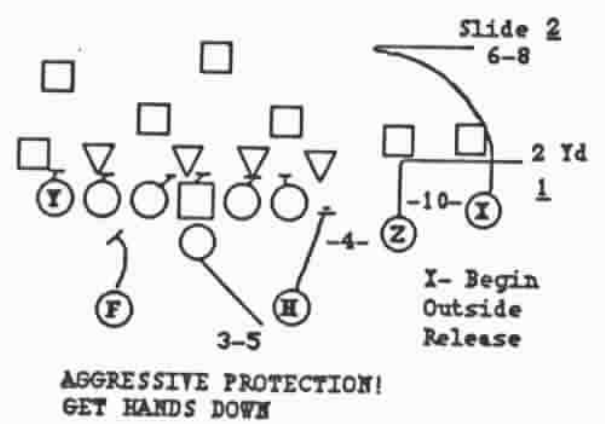

(5)

RED LEFT
FAKE 19 QB KEEP FB SLIDE

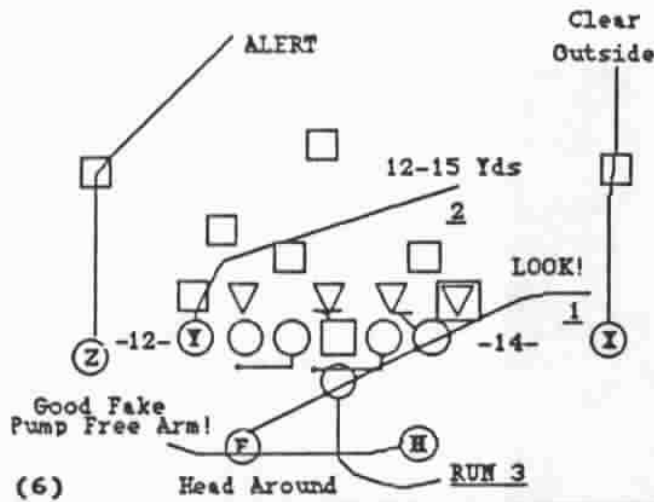

MOVEMENT

(T) SOLO LEFT
P. 97 SOLID SEATTLE (9)

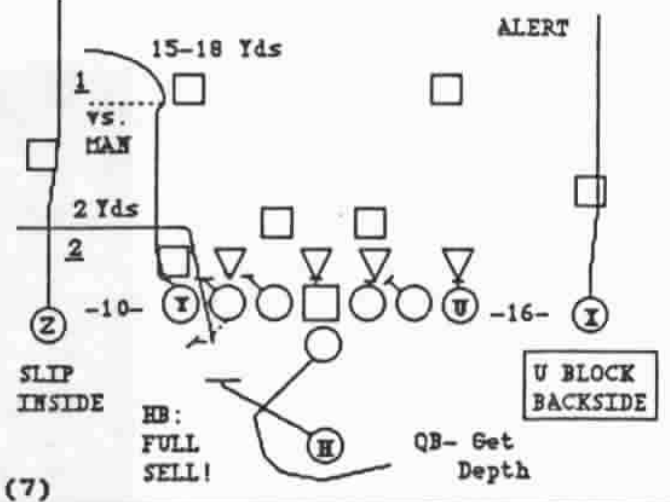

SCREENS

RED LEFT SLOT
SPRINT RIGHT FB SLOW SCREEN LEFT

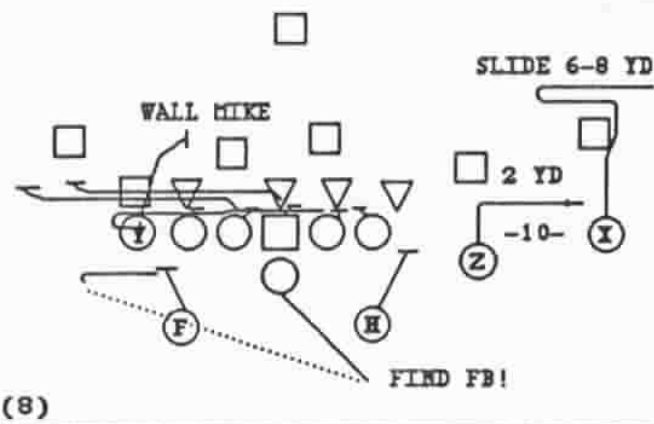

NICKEL

(E) DOUBLE WING RIGHT
22 SCAT 'E' OPTION

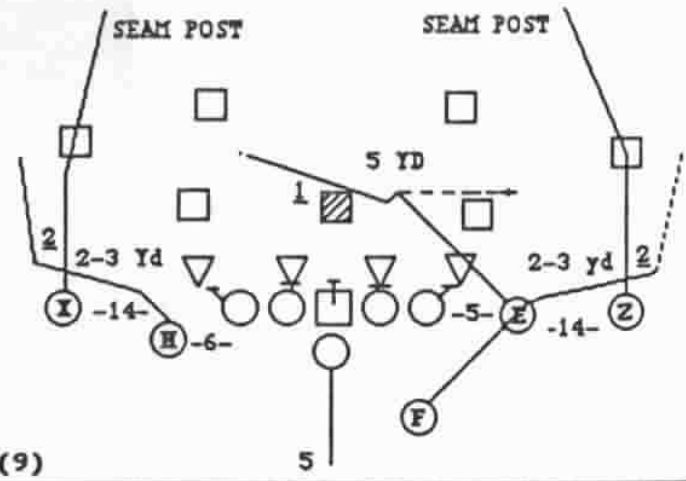

(EAG) SPREAD LEFT
300 JET LION/SLUGGO

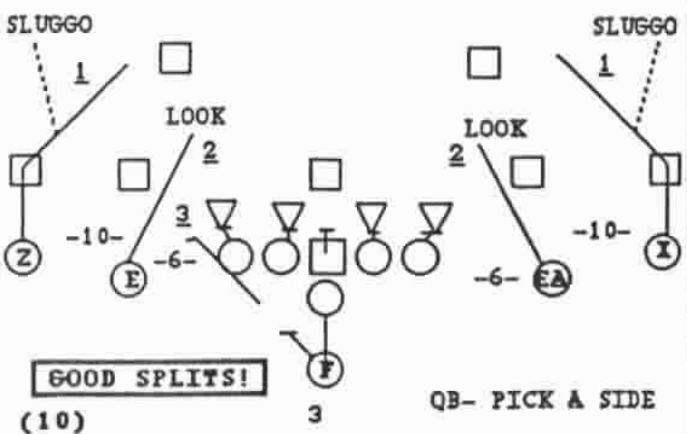

(ZEB) DOUBLE WING LEFT 'ZEB' LEFT
3 JET SEATTLE

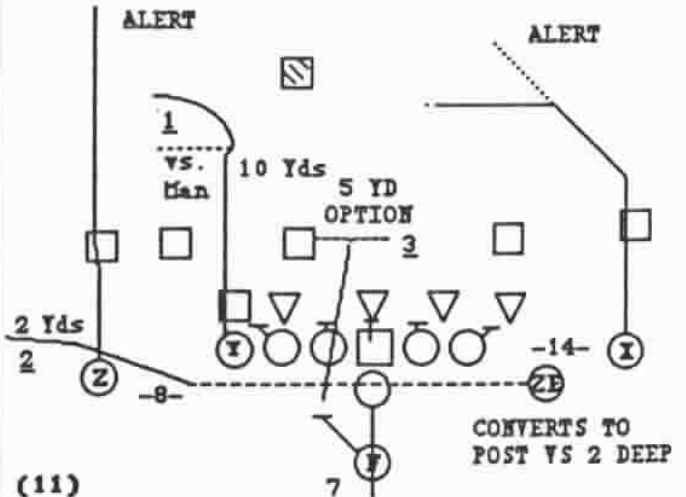

(ZEB) TRIPS LEFT
3 JET 'ZEB' DRIVE 'Z' POST

NICKEL

(EAG) SPREAD RIGHT
3 JET WINSTON 'E' CROSS

(10)

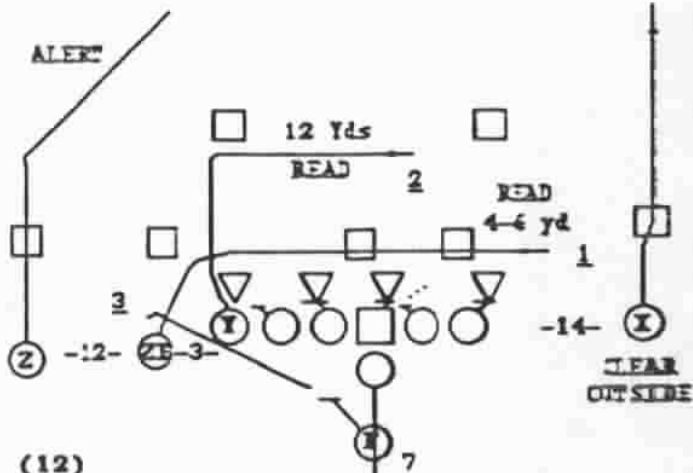

(12)

POSSIBLE 'Z' CALL

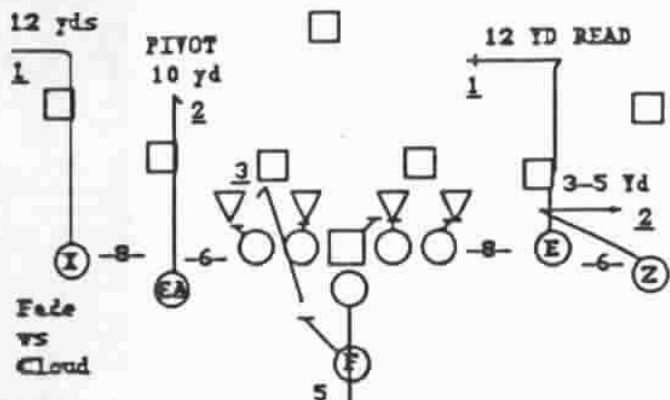

(13)

(EAG) SPREAD LEFT
3 JET DOUBLE ARROW "EAGLE" CROSS

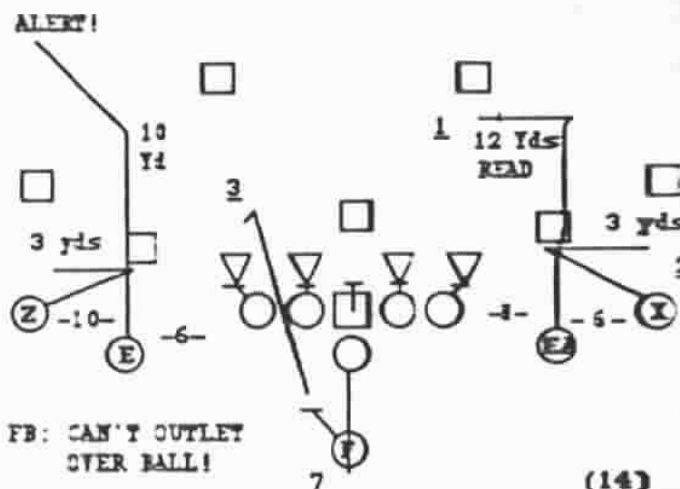

(14)

(EAG) SPREAD RIGHT
2 JET ALL GO (FK FB40)

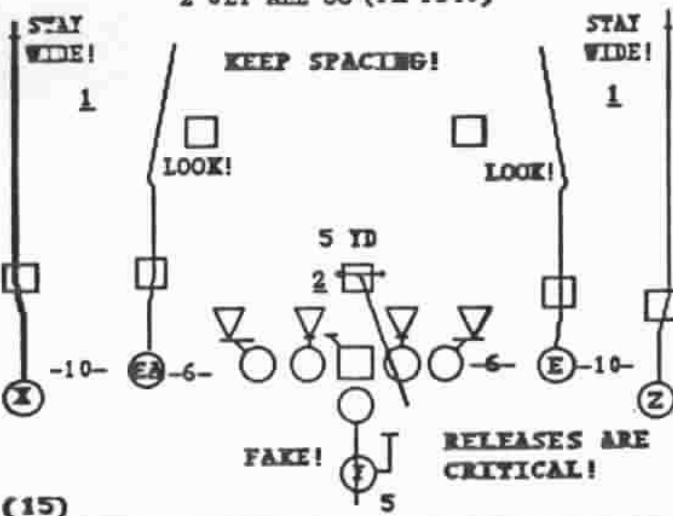

(15)

(ZEB) TRIPS RIGHT
2 JET ALL GO SPECIAL (FK FB40)

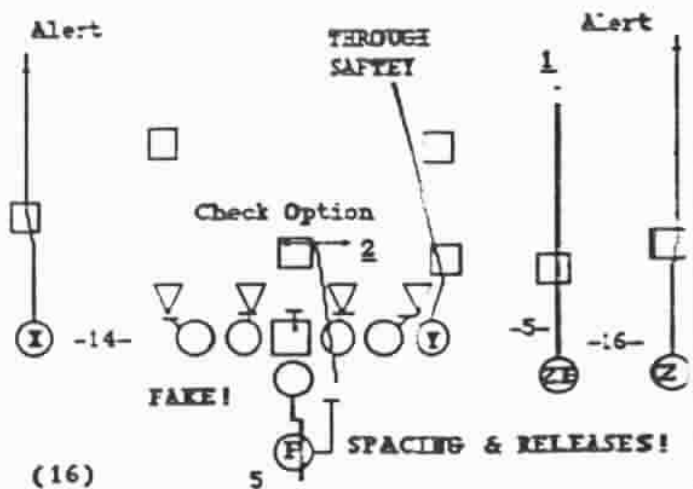

(16)

42 KING

13-14 DRAW

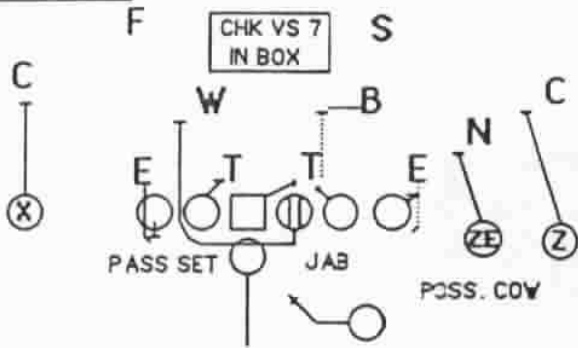

(ZEB) TRIPS RIGHT 15 DRAW

41

10-40-41

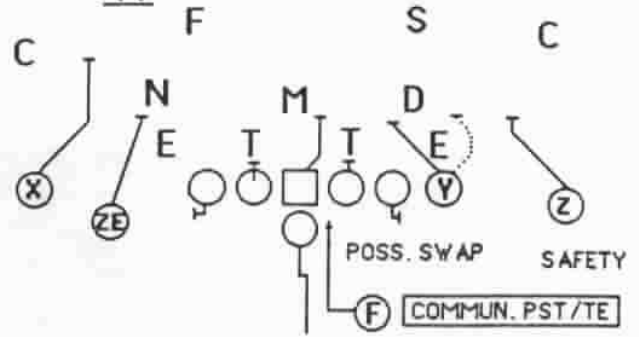

(ZEB) DOUBLE WING RIGHT FB 40

42 QUEEN

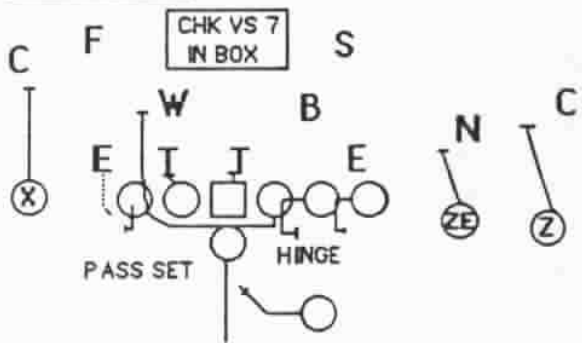

(ZEB) TRIPS RIGHT 15 DRAW

41 QUEEN

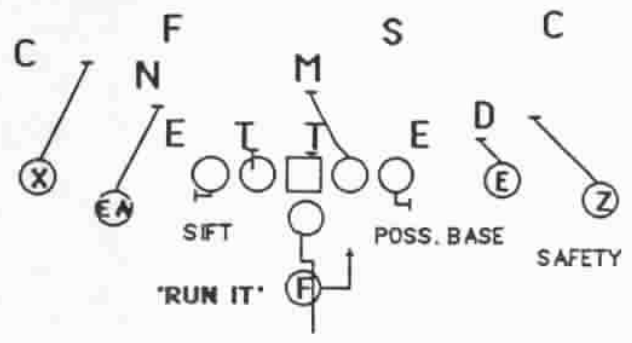

(EAG) SPREAD RIGHT FB 40

41

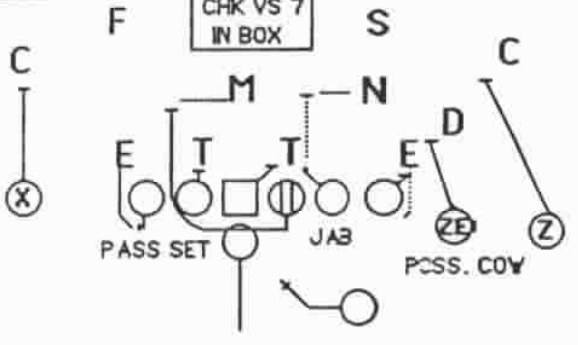

(ZEB) TRIPS RIGHT 15 DRAW

41 KING

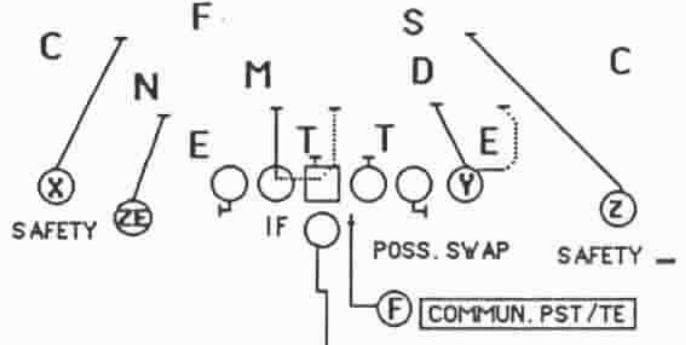

(ZEB) DOUBLE WING RIGHT FB 40

42

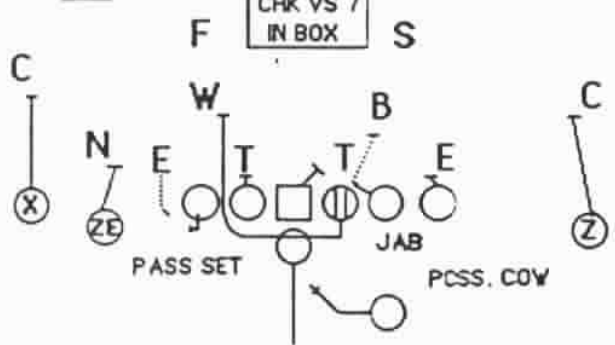

(ZEB) DOUBLE WING RIGHT 15 DRAW

42

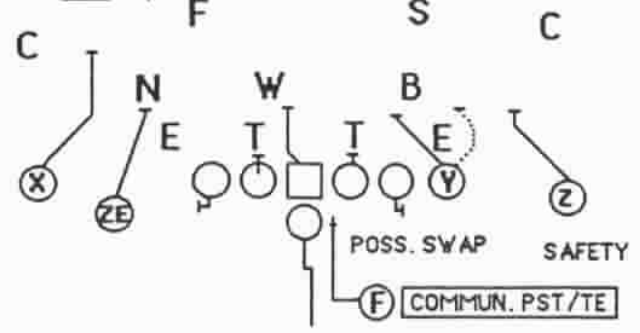

(ZEB) DOUBLE WING RIGHT FB 40

67-66 SLANT

NI RUNS

66-67 'T'

41

F S

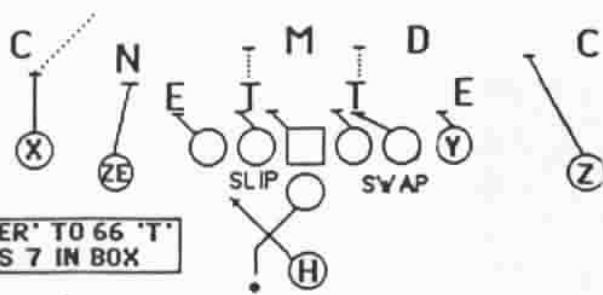

(ZEB) DBL WING RIGHT 67 SLANT

41

F S

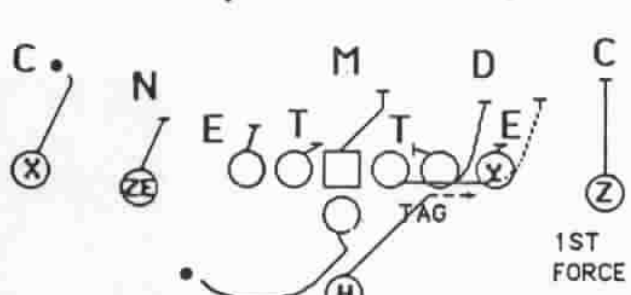

(ZEB) DBL WING RIGHT 66 'T'

41 QUEEN

F S

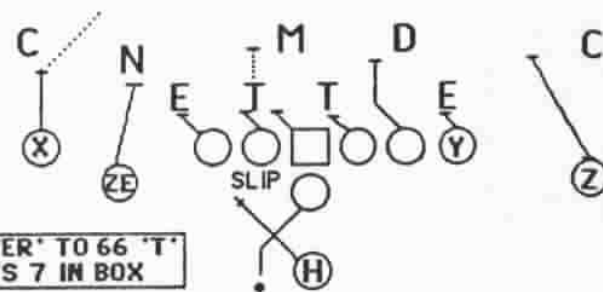

(ZEB) DBL WING RIGHT 67 SLANT

41 QUEEN

F S

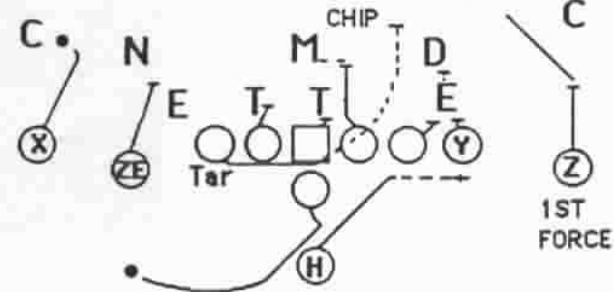

(ZEB) DBL WING RIGHT 66 'T'

41 KING

F S

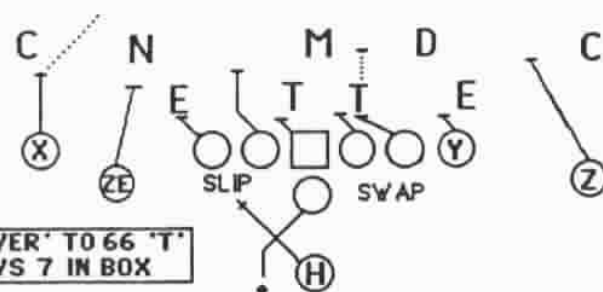

(ZEB) DBL WING RIGHT 67 SLANT

41 KING

F S

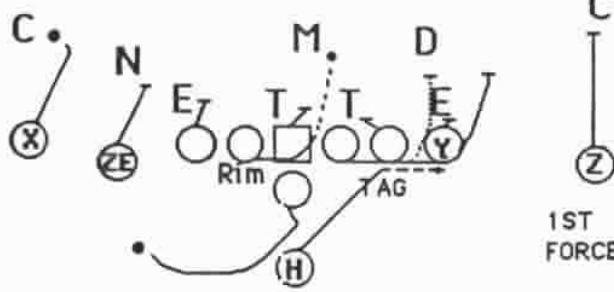

(ZEB) DBL WING RIGHT 66 'T'

42

F S

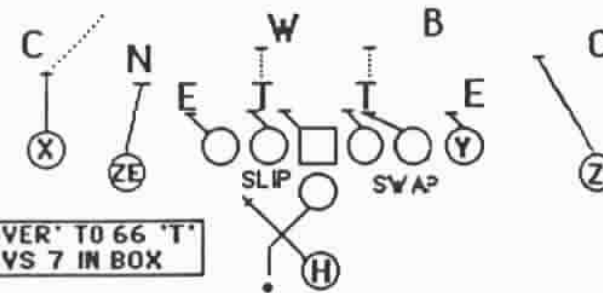

(ZEB) DBL WING RIGHT 67 SLANT

42

F S

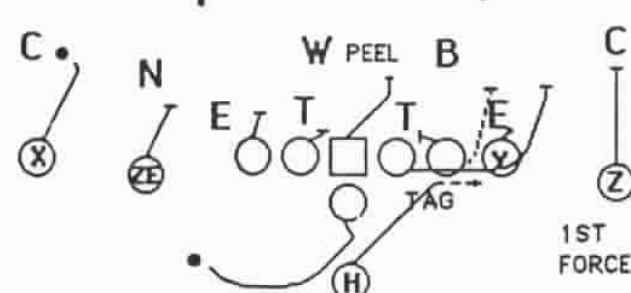

(ZEB) DBL WING RIGHT 66 'T'

42

60-61 TRAP

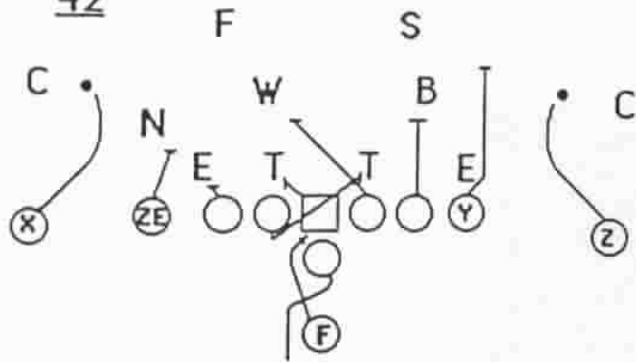

(ZEB) DOUBLE WING RIGHT 60 TRAP

41

68-69 'H0' SOLID

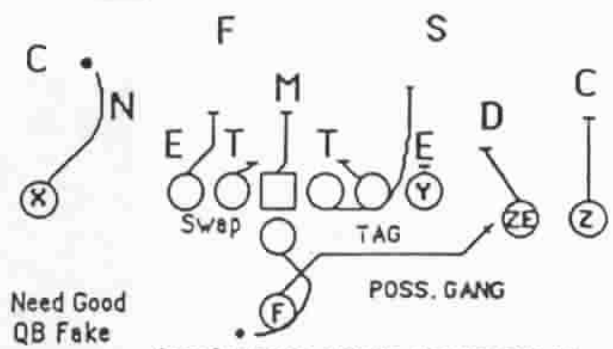

Need Good QB Fake

(ZEB) TRIPS RIGHT 68 HO SOLID

41 QUEEN

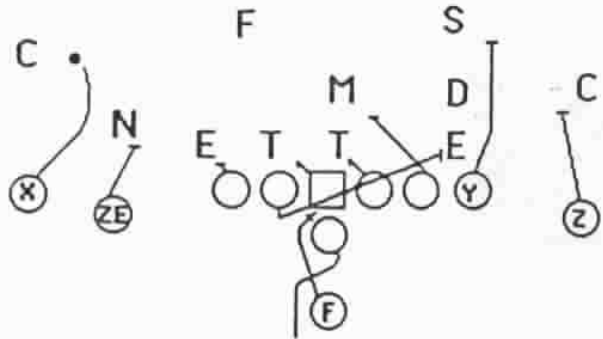

(ZEB) DOUBLE WING RIGHT 60 TRAP

41 QUEEN

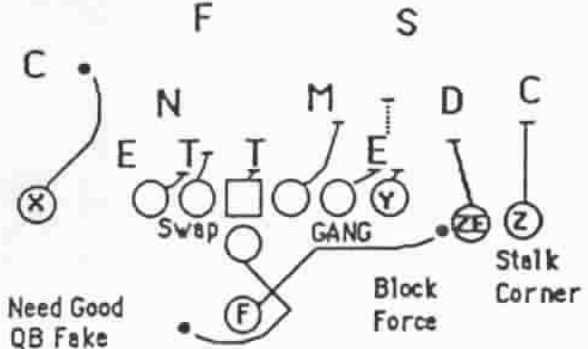

Need Good QB Fake

(ZEB) TRIPS RIGHT 68 HO SOLID

41 KING

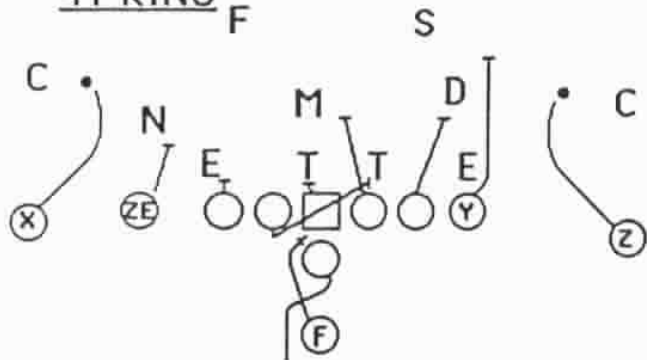

(ZEB) DOUBLE WING RIGHT 60 TRAP

41 KING

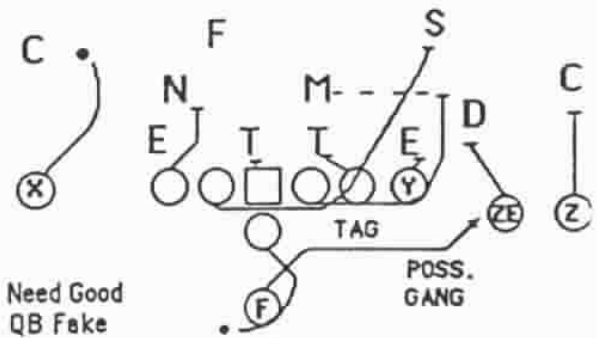

Need Good QB Fake

(ZEB) TRIPS RIGHT 68 HO SOLID

41

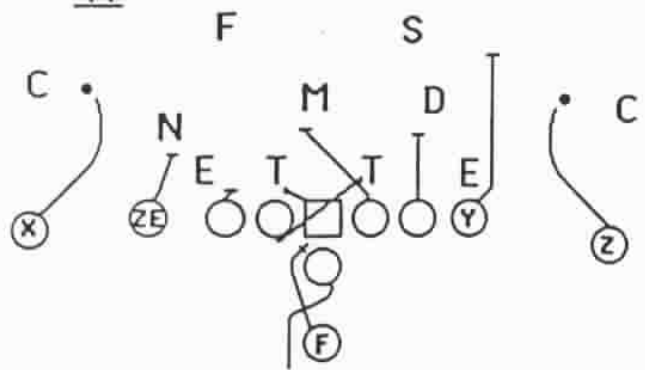

(ZEB) DOUBLE WING RIGHT 60 TRAP

Mini Camp - DAY 4

BASE PASSES:

1. 20-21 BINGO BACKS LT/RT -- RED
2. 22-23 'Z' IN 'Y' GO -- RED
3. 300 JET 'X' SLUGGO 'Z' SEAM -- HB FAR TRIPS LEFT
4. 2-3 JET DINO 'Y' SHALLOW CROSS -- BROWN SLOT 'A-C' STRONG

PLAY PASSES:

5. FOX 2 WEAK 'X' SQ. OUT -- BLUE LEFT

MOVEMENT PASSES:

6. FK. FOX 3 WEAK QB KEEP RIGHT -- BLUE RIGHT 'Y' MOTION
DRAG SLIDE

NICKEL PASSES:

7. 2-3 JET SCAT SCRAPE 'E' OUT -- (EAG) SPREAD 'EAG' STRONG
8. 2-3 JET 'X' DAGGER -- (ZEB) FAR WEST SLOT
9. 2-3 JET DOUBLE 'Z' -- (EAG) SPREAD
10. 2-3 JET SCAT HB OPTION -- (EAG) SPREAD
11. 2-3 JET HB SLOW SCREEN WEAK -- (EAG) SPREAD 'EAG' STRONG

RED RIGHT
20 BINGO "BACKS LEFT"

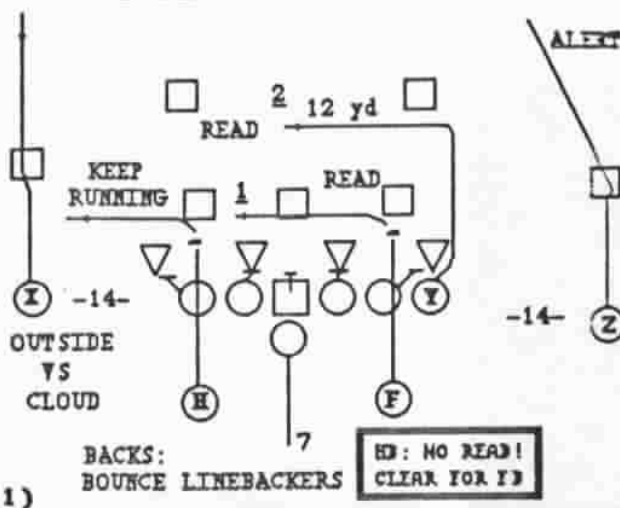

(1)

BASE

RED RIGHT
22 'Z' IN 'Y' 60

(11)

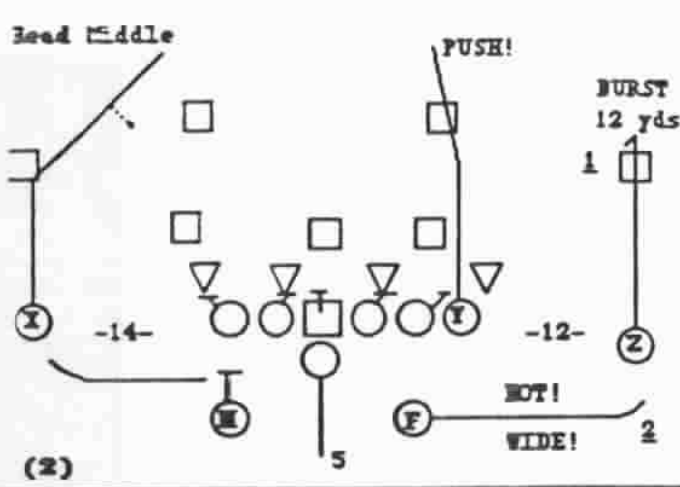

(2)

HB FAR TRIPS LEFT
300 JET "X" SLUGGO "Z" SEAM

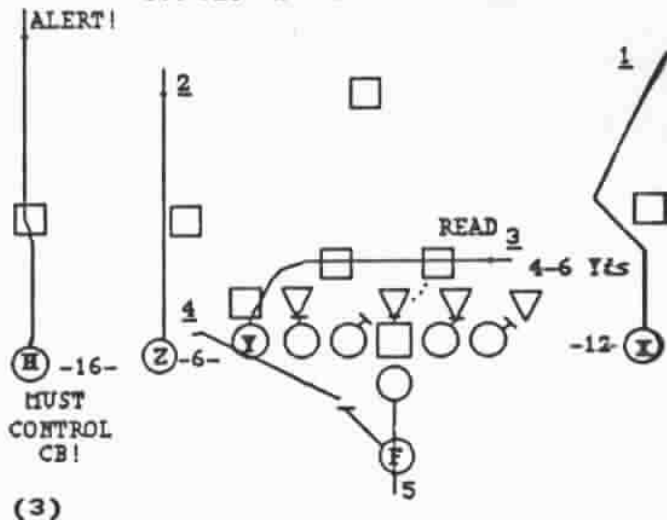

(3)

BROWN LEFT SLOT 'C' LEFT
3 JET BROWN 'Y' SHALLOW CROSS

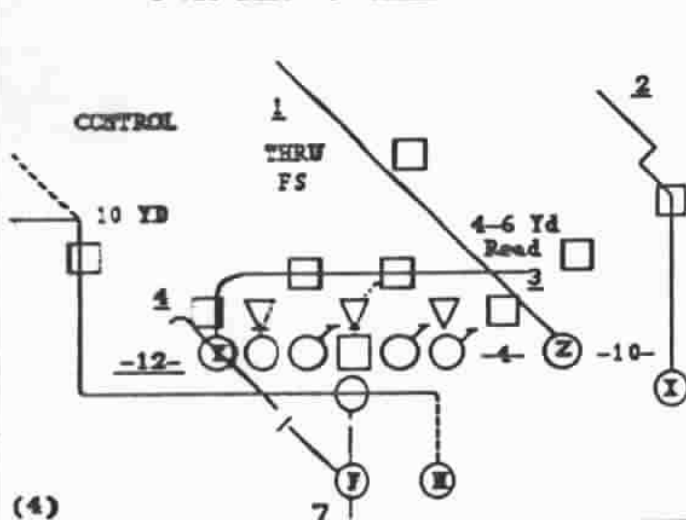

(4)

PLAY PASS

BLUE LEFT
FOX 2 WEAK 'X' SQUARE OUT

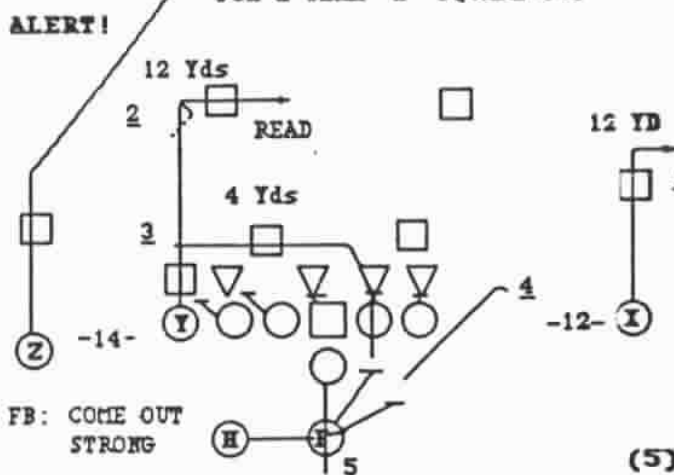

(5)

MOVEMENT

BLUE RIGHT 'Y' MOTION
FAKE FC 3 WK QB KEEP DRAG SLIDE

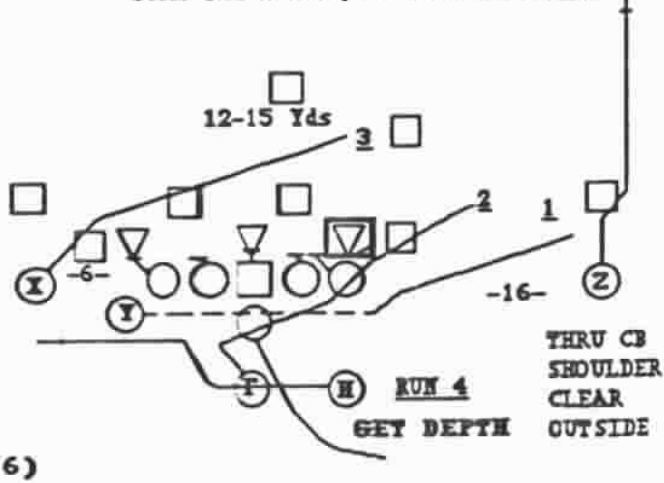

(6)

(EAG) SPREAD RIGHT 'EAG' RIGHT
3 JET SCAT SCRAPE "E" OUT

NICKEL

(ZEB) FAR WEST LEFT SLOT
3 JET 'X' DAGGER

(12)

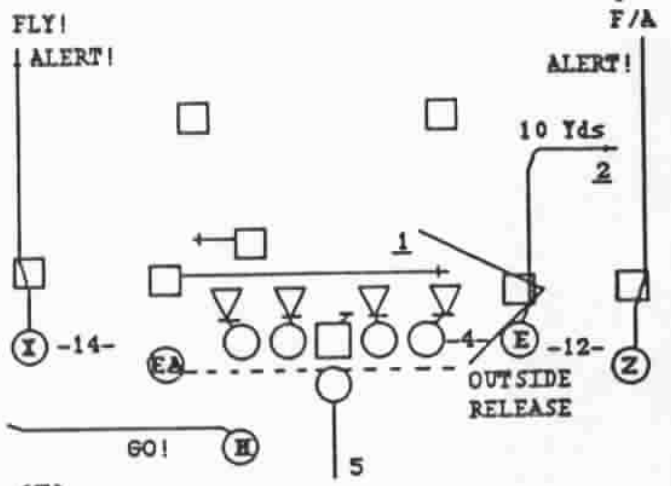

(7)

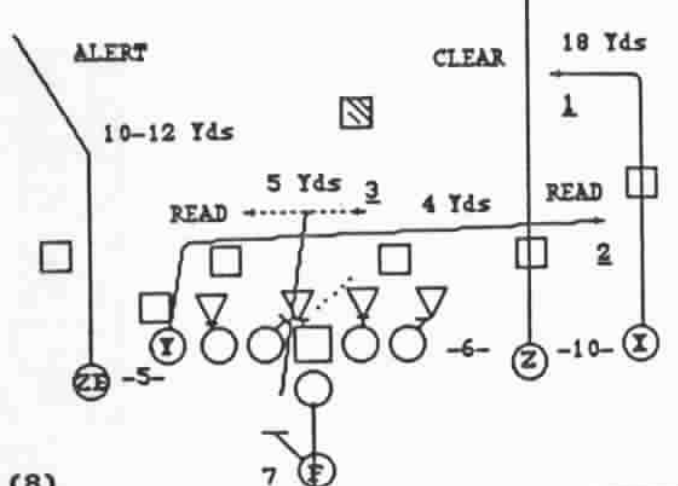

(8)

(EAG) SPREAD LEFT
3 JET DOUBLE 'Z'

(EAG) SPREAD RIGHT
2 JET SCAT HB OPTION

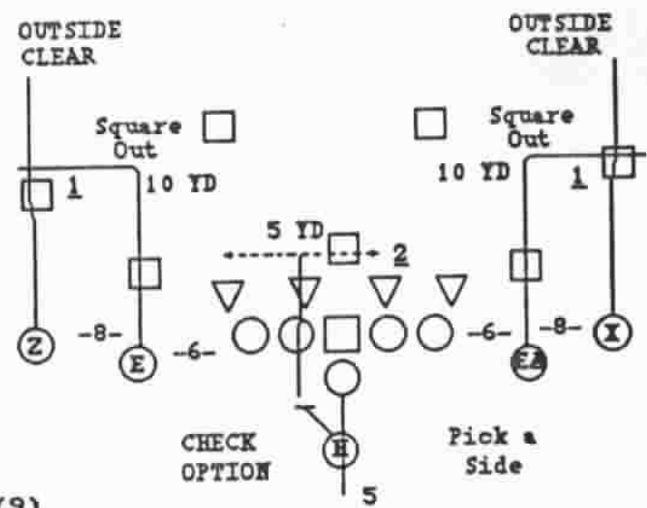

(9)

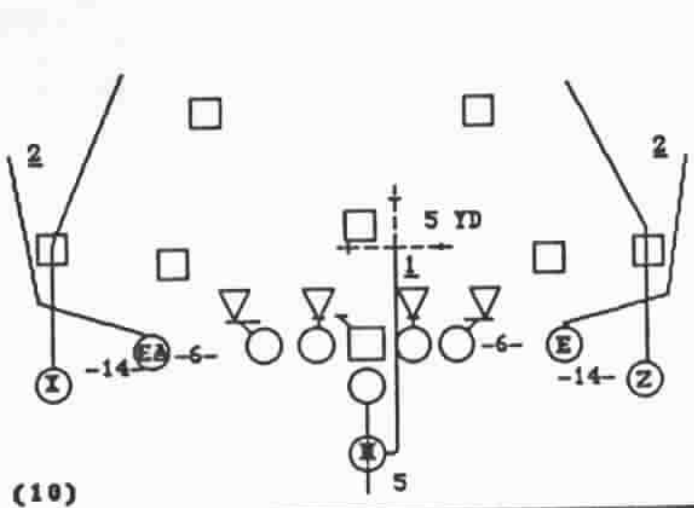

(10)

(EAG) SPREAD RIGHT EAGLE RIGHT
3 JET HB SLOW SCREEN LEFT

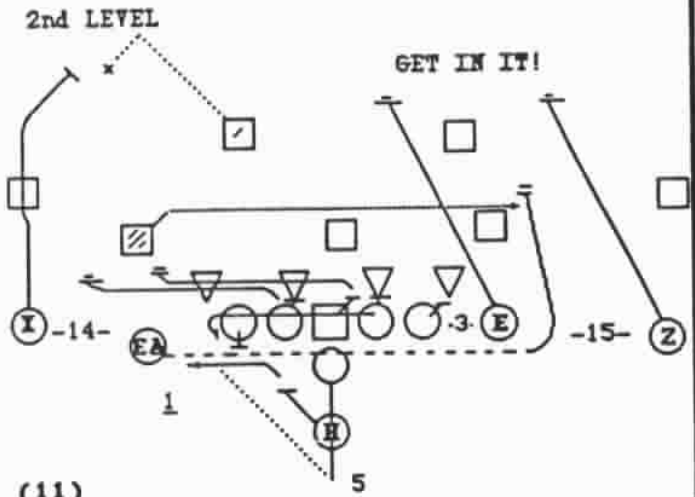

(11)

Mini Camp - DAY 1

BASE PASSES:

1. 324-325 OM / TH / SM / TRAIN -- RED
-- RED SLOT
2. 20-21 BINGO BACKS LT/RT -- RED 'Y' MOTION (POS. 'Y' SHIFT)
3. 322-323 (SCAT) 'Y' STICK -- FB WEST ZOOM SHORT
-- (T) SOLO SLOT 'A-C' STRONG
-- (ZEB) EAST 'F' WEAK
4. 22-23 'Y' CROSS FB FAN -- RED 'Y' SHORT
5. 22-23 'X' SHALLOW CROSS -- HB NORTH 'HB' STRONG
6. 24-25 DBL CB/DIG/GO/S.O. -- GREEN / RED 'Y' SHIFT
7. 2-3 JET 'FLK' DRIVE -- BLUE 'Y' SHORT

PLAY PASSES:

8. 75 HB SEAM FK SCREEN RT. -- BROWN LEFT
9. P. 317 'X' SLANT -- RED LEFT

SCREEN PASSES:

10. S-9 -- RED RIGHT

RUNS:

1. 92-93 LEAD -- GREEN / GREEN SLOT
2. 93-92 BLAST -- GREEN / GREEN SLOT
3. 96-97 'F' CTR GAP -- GREEN
4. 97-96 'F' STUTTER -- GREEN
5. FB 40-41 -- RED / RED SLOT
-- (ZEB) DBL WING (STR/WK)
-- (EAG) SPREAD
6. 18-19 BOB -- RED / RED SLOT

(T) SOLO RIGHT SLOT 'A' RIGHT
322 SCAT 'Y' STICK

BASE

(ZEB) EAST RIGHT 'F' LEFT (2)
322 'Y' STICK

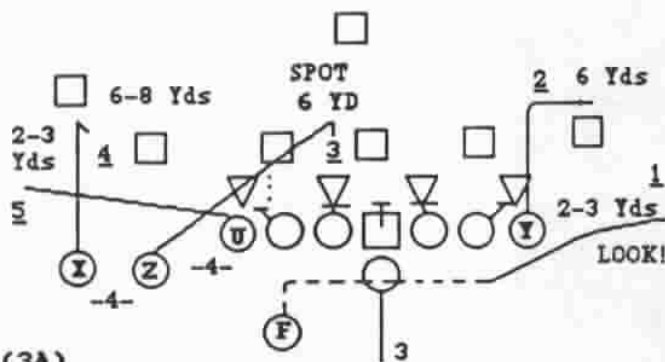

(3A)

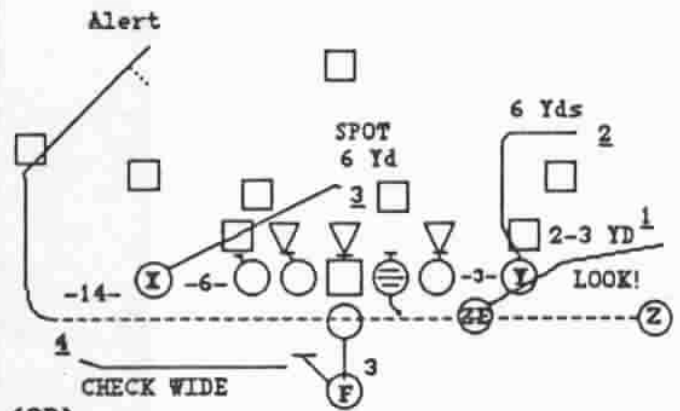

(3B)

RED RIGHT 'Y' SHORT
22 'Y' CROSS FB FAN

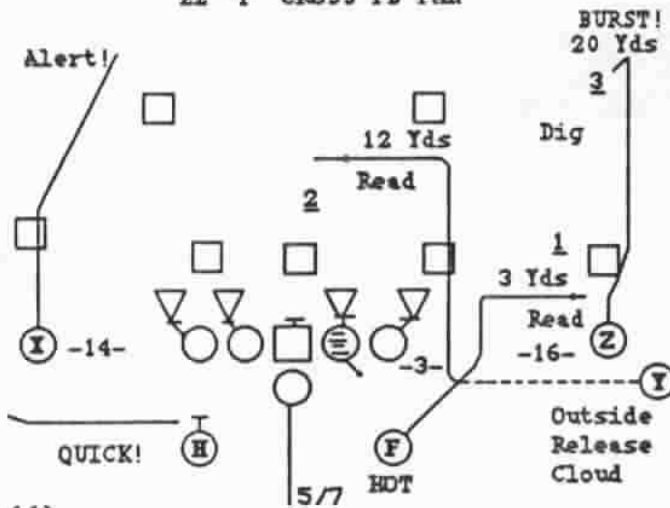

(4)

HB NORTH RIGHT 'HB' RIGHT
22 'X' SHALLOW CROSS

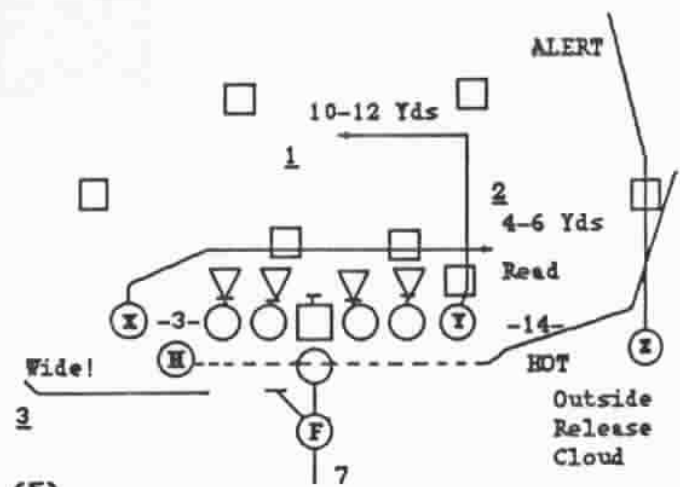

(5)

GREEN RIGHT
24 DOUBLE CB/DIG/GO
(ALSO RED 'POS. 'Y' SHIFT')

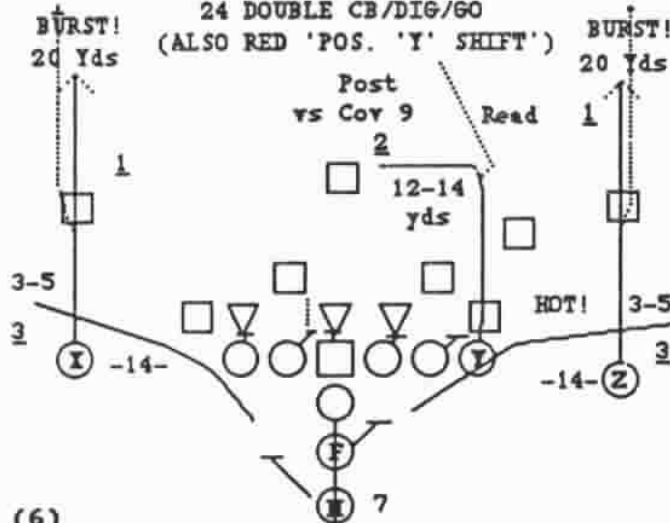

(6)

GREEN RIGHT
24 DOUBLE SQUARE OUT
(ALSO RED 'POS. 'Y' SHIFT')

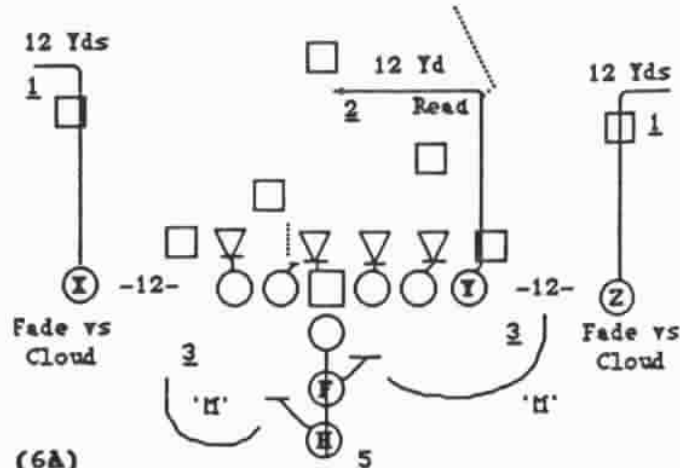

(6A)

BASE

BLUE RIGHT 'Y' SHORT
2 JET FLANKER DRIVE

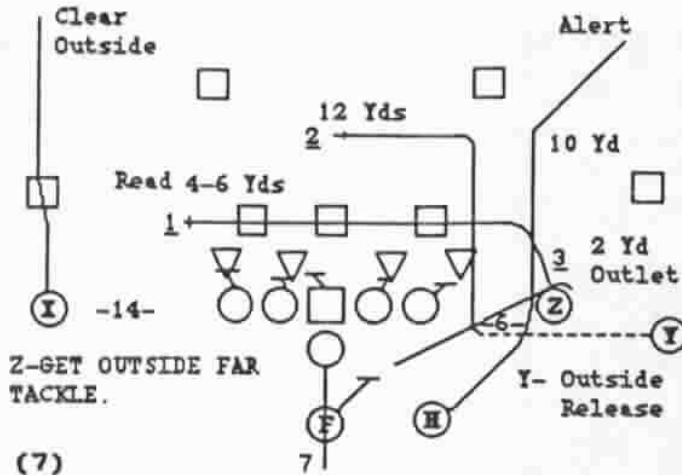

(7)

PLAY PASS

BROWN LEFT (3)
75 HB SEAM FK. SCREEN RIGHT

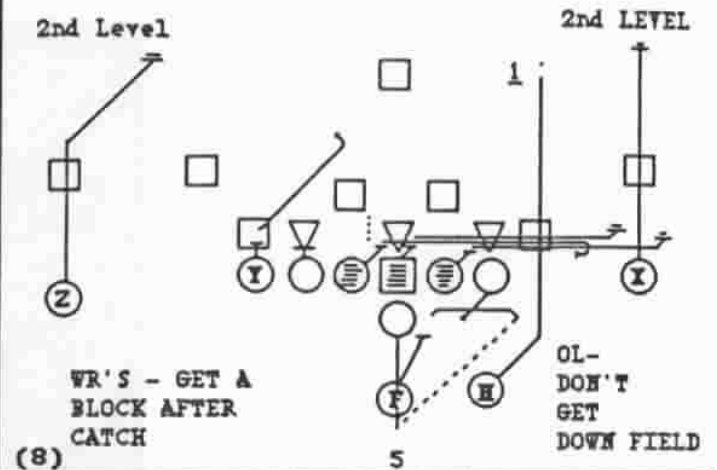

(8)

RED LEFT
PASS 317 "X" SLANT

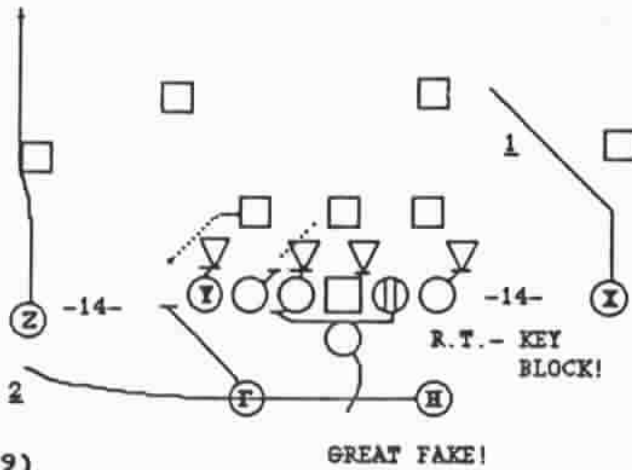

(9)

SCREENS

RED RIGHT
S-9

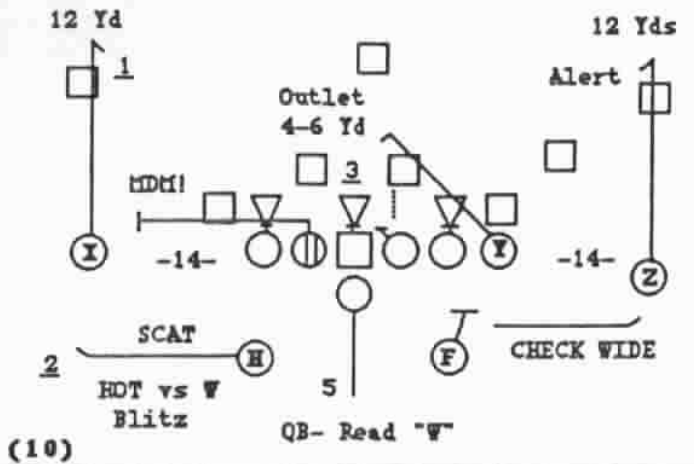

(10)

92-93 LEAD

49

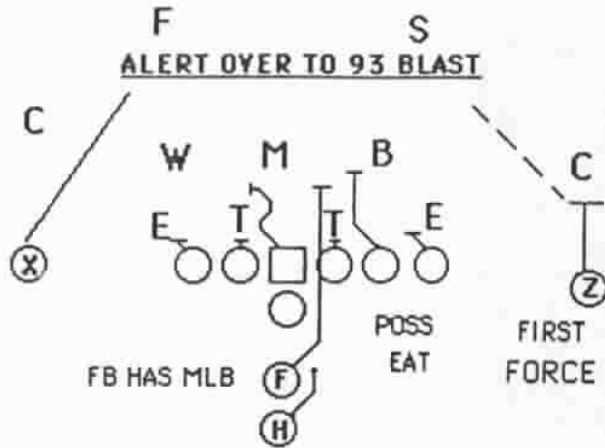

GREEN RT 92 LEAD

43

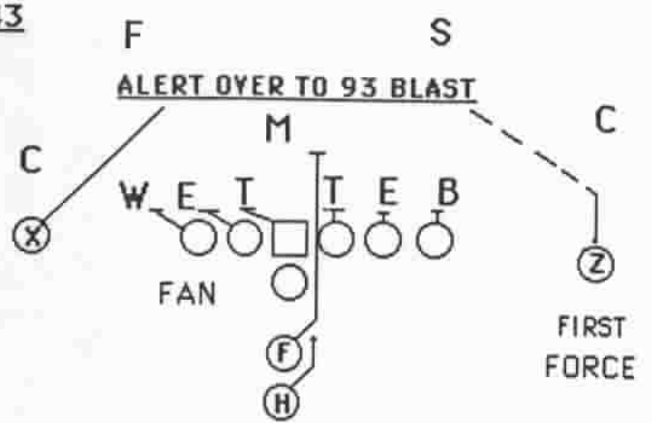

GREEN RT 92 LEAD

25 (35)

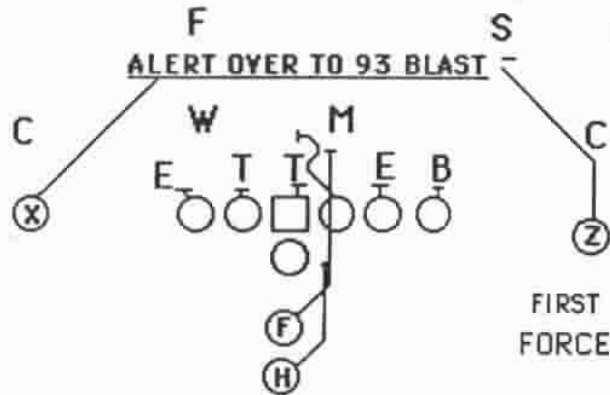

GREEN RT 92 LEAD

57 (37)

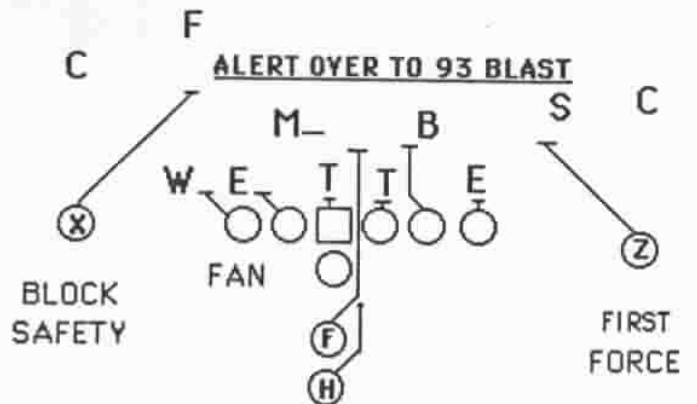

GREEN RT 92 LEAD

59

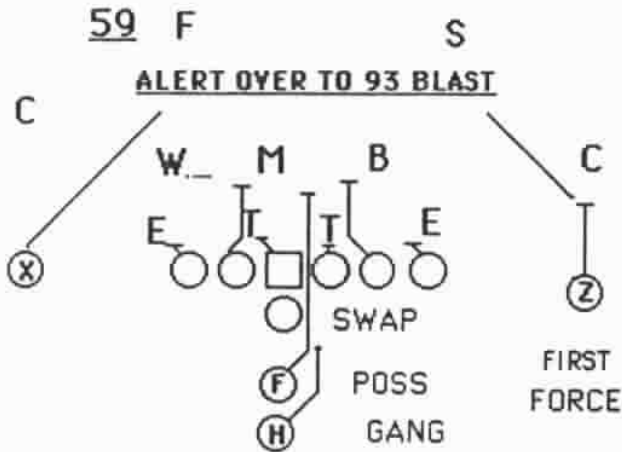

GREEN RT 92 LEAD

42

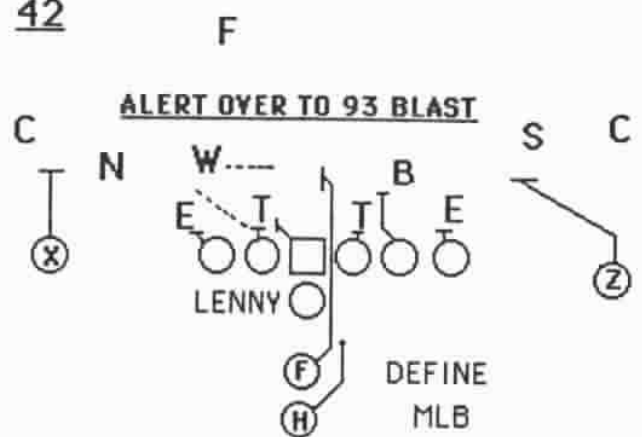

GREEN RT 92 LEAD

93-92 BLAST

49

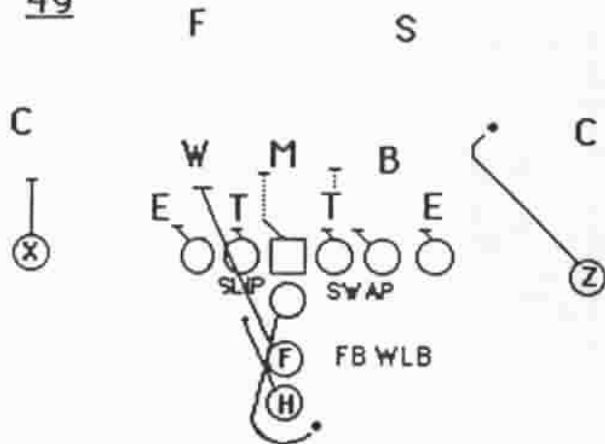

GREEN RIGHT 93 BLAST

43

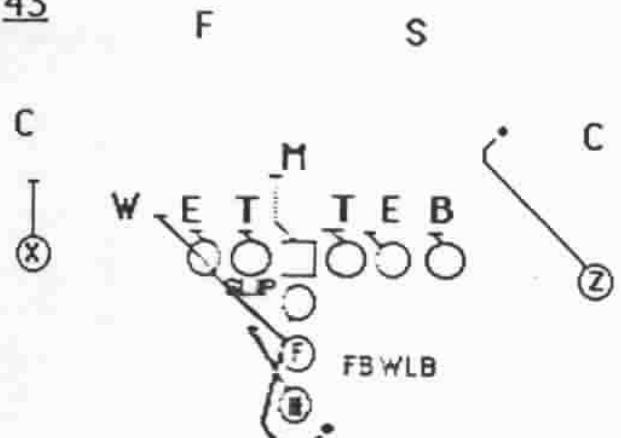

GREEN RIGHT 93 BLAST

25 (35)

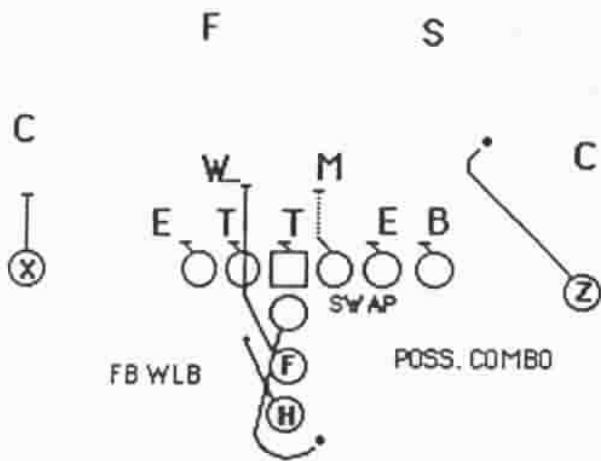

GREEN RIGHT 93 BLAST

57 (37)

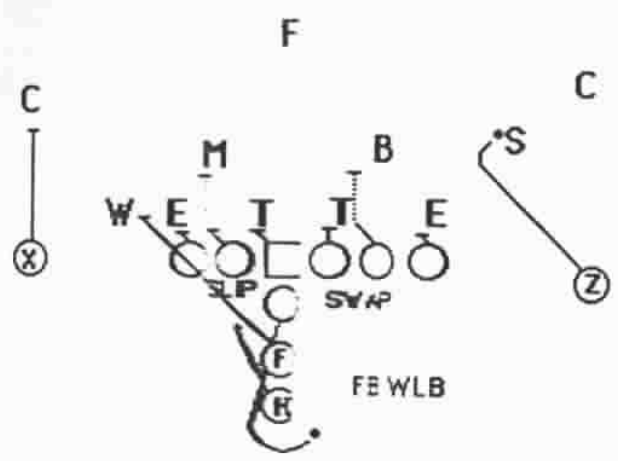

GREEN RIGHT 93 BLAST

59

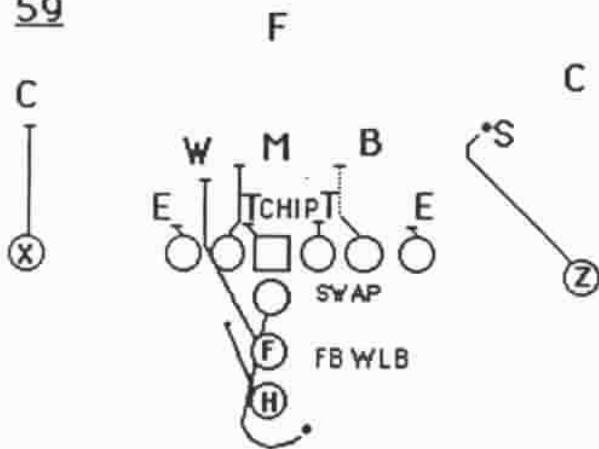

GREEN RIGHT 93 BLAST

42

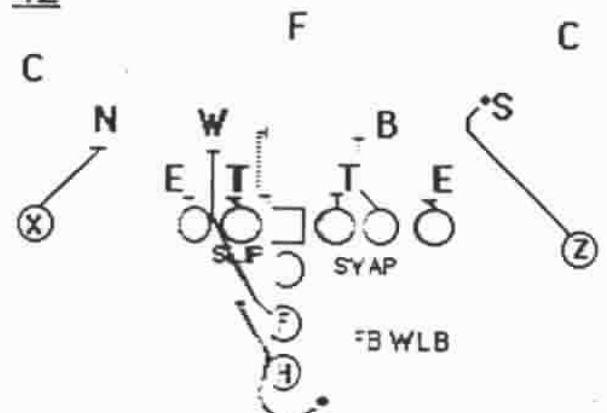

GREEN RIGHT 93 BLAST

96-97 'F' CTR GAP

49

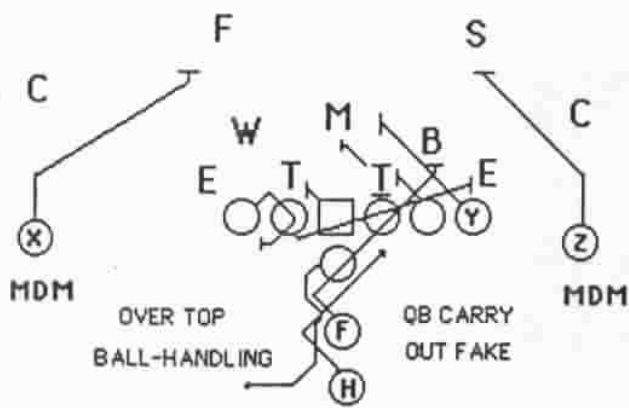

GREEN RIGHT 96 'F' CTR

43

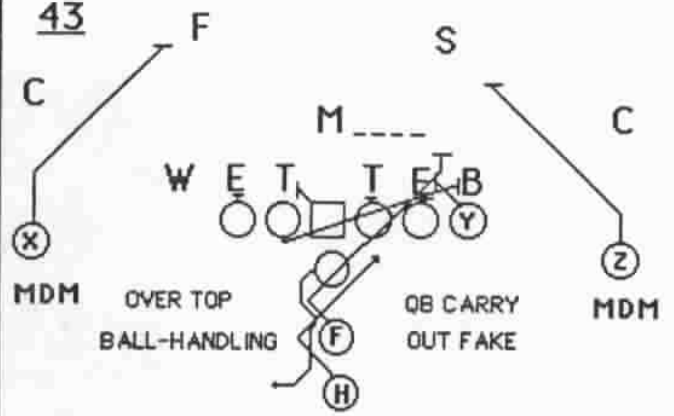

GREEN RIGHT 96 'F' CTR

25 (35)

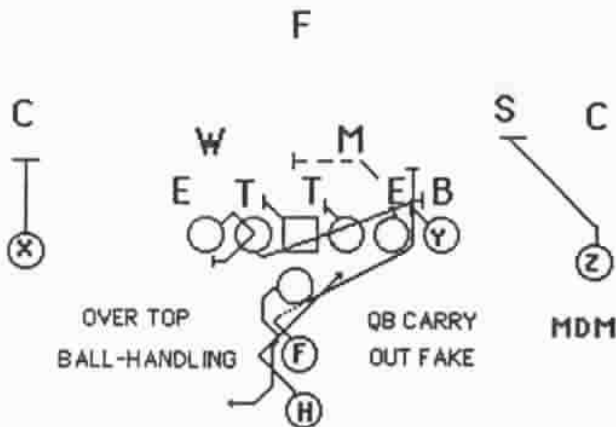

GREEN RIGHT 96 'F' CTR

57 (37)

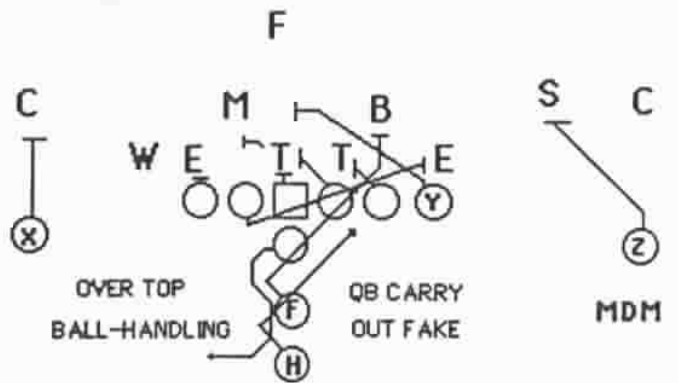

GREEN RIGHT 96 'F' CTR

59

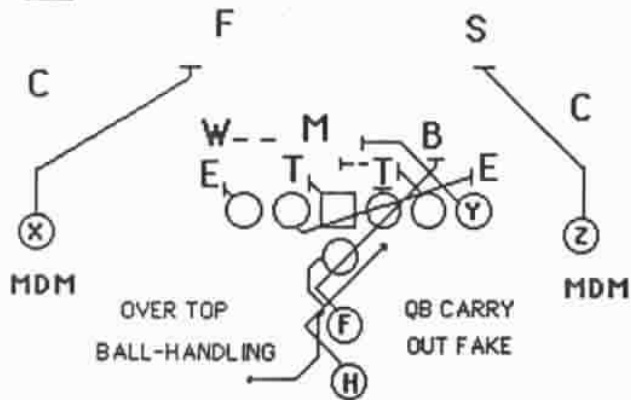

GREEN RIGHT 96 'F' CTR

97-96' STUTTER

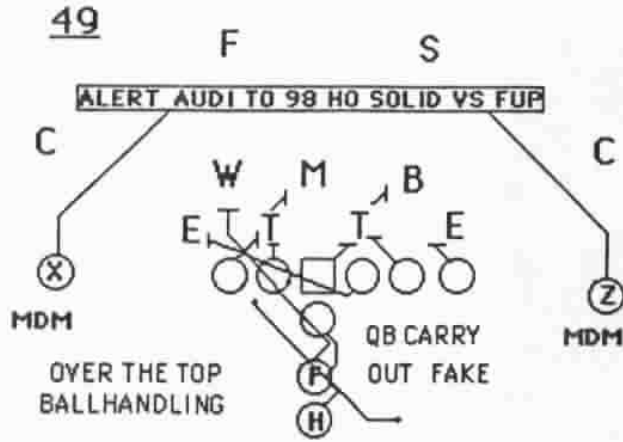

GREEN RIGHT 97 'F' STUTTER

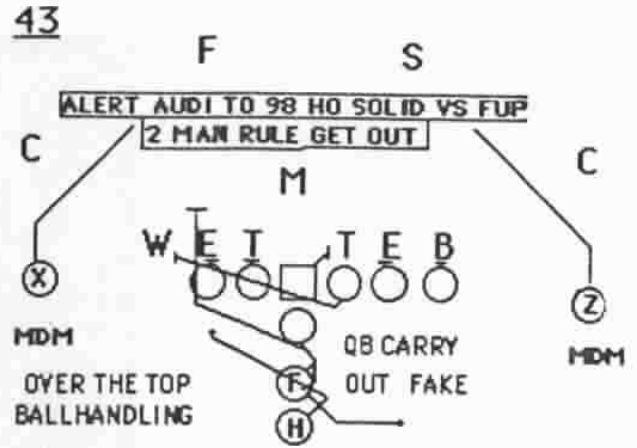

GREEN RIGHT 97 'F' STUTTER

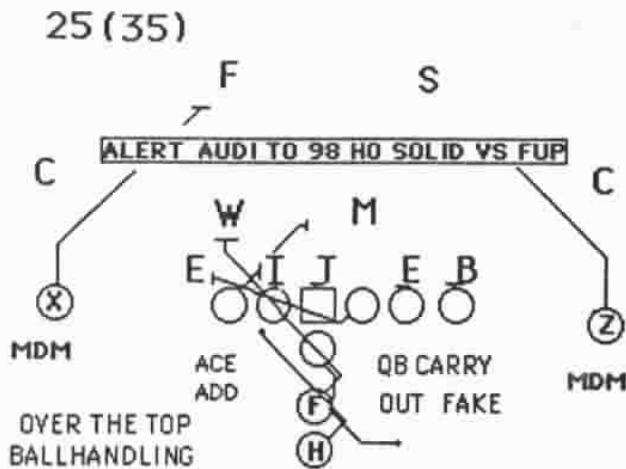

GREEN RIGHT 97 'F' STUTTER

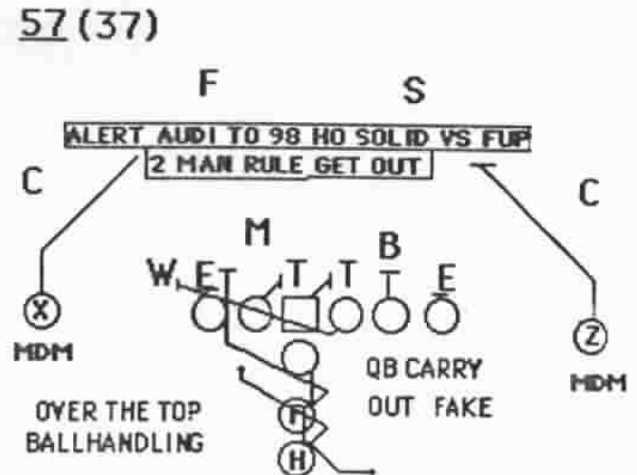

GREEN RIGHT 97 'F' STUTTER

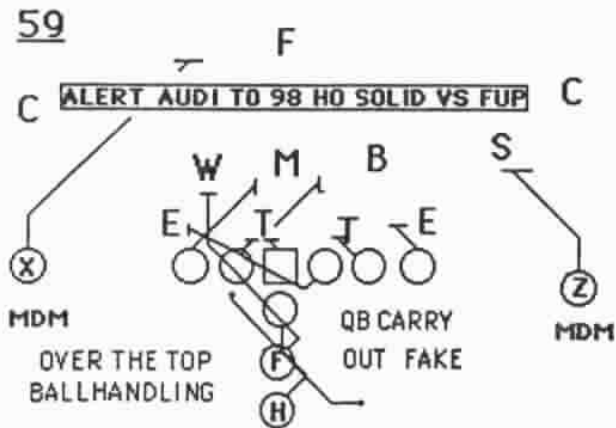

GREEN RIGHT 97 'F' STUTTER

FB 40-41

49

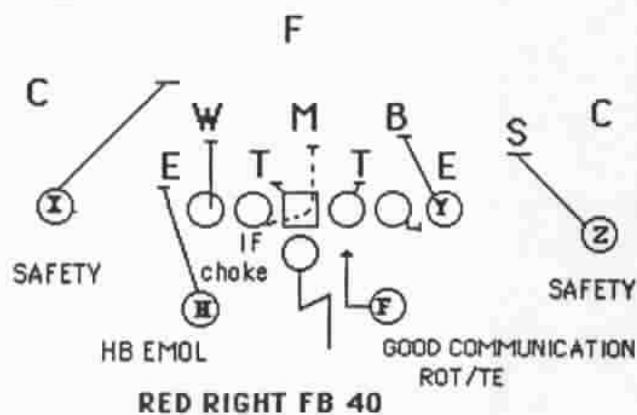

43

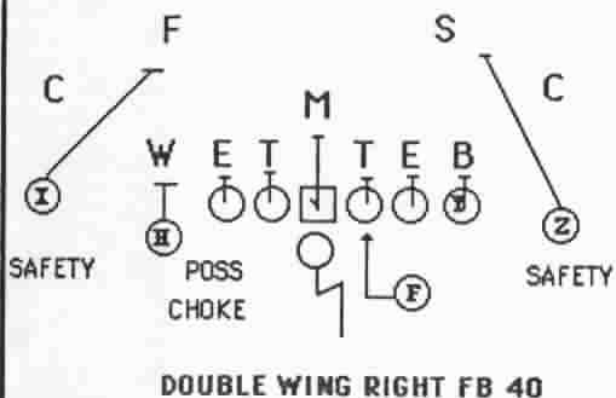

25 (35)

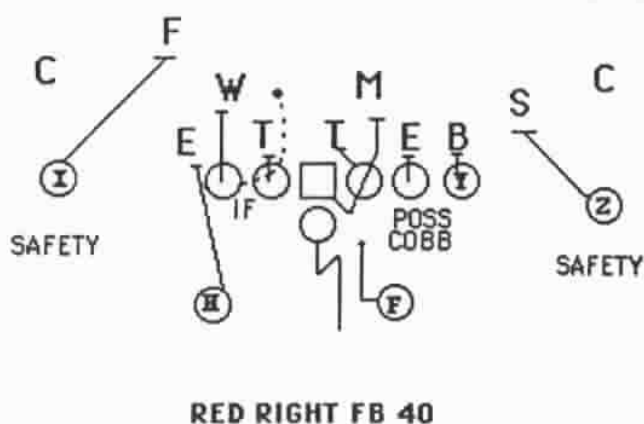

41 KING

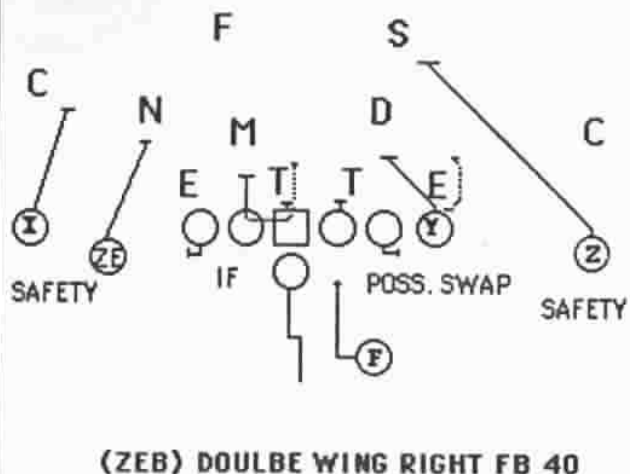

59

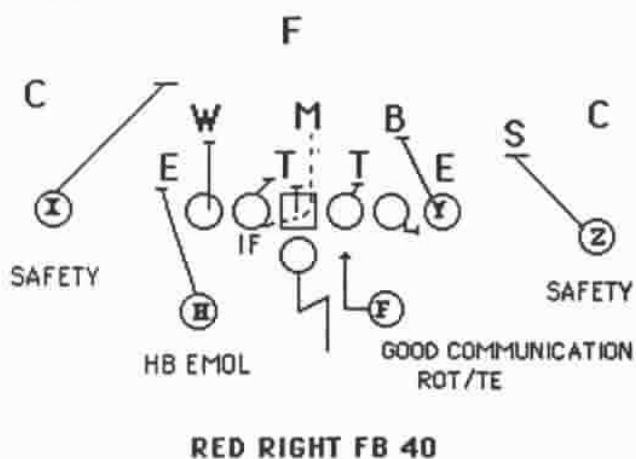

41 QUEEN

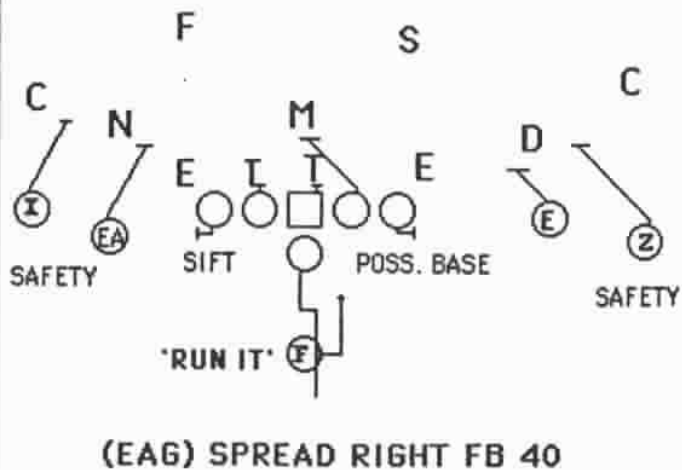

18-19 BOB

49

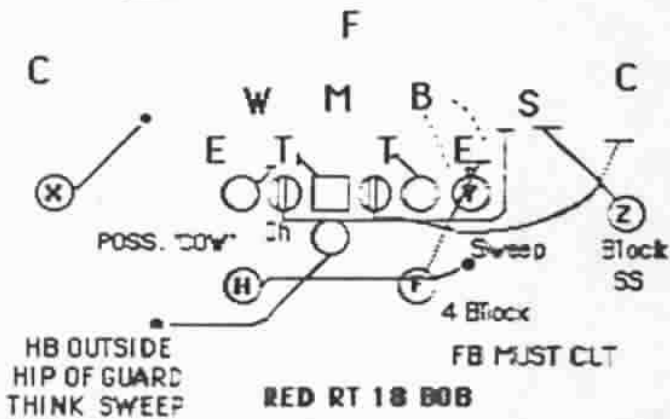

43

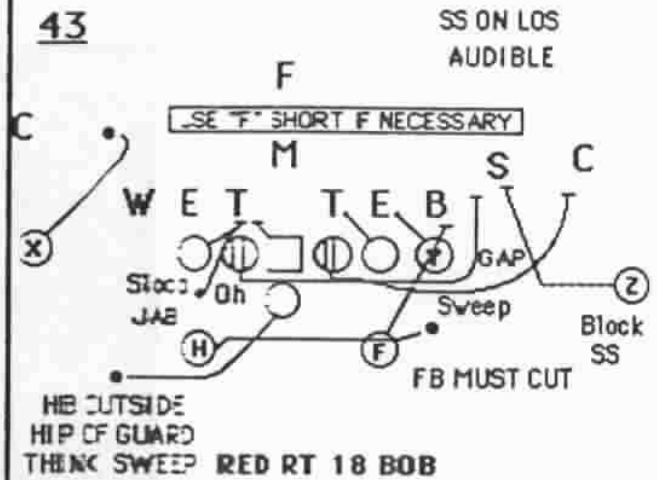

25 (35)

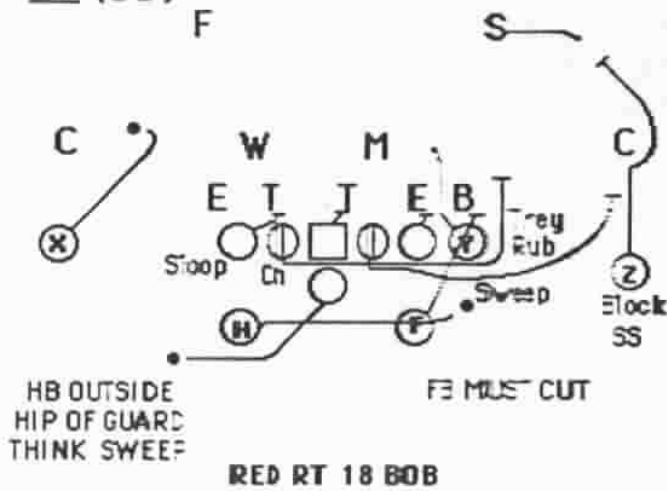

57 (37)

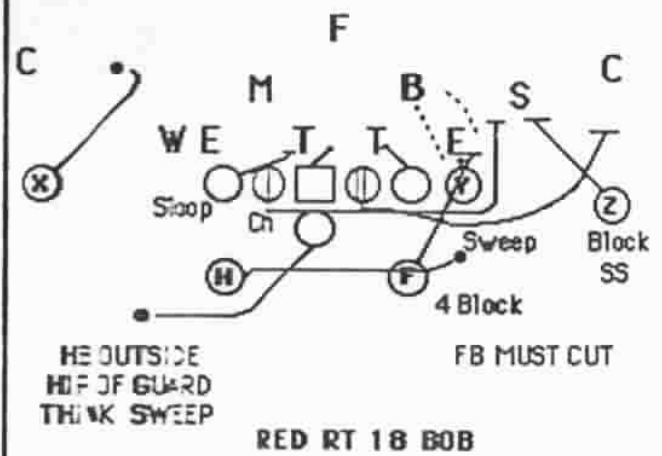

59

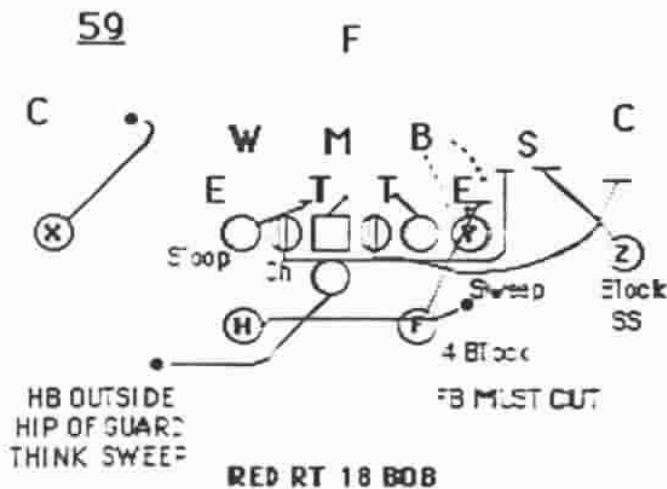

42

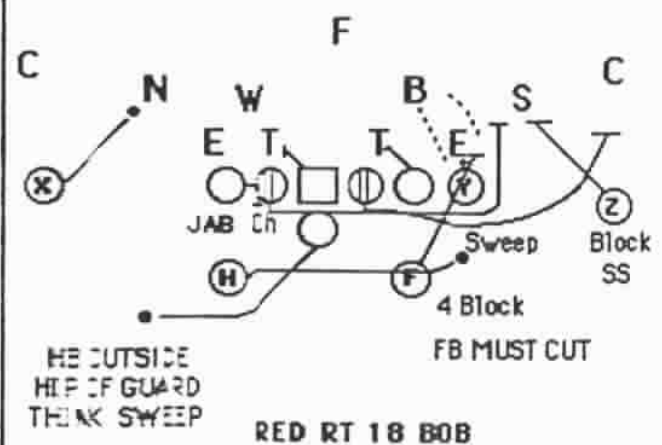

Mini Camp - DAY 2

BASE PASSES:

1. 20-21 BINGO CROSS -- RED
-- RED 'Z' STRONG
2. 22-23 'Y' STICK -- BROWN 'B' STRONG
3. 22-23 SEATTLE -- FB WEST 'FB' CTR MOTION
4. 50-51 'X' SPOT -- (T) EAST SLOT 'U' CTR MOTION
5. 74-75 DBL CB/DIG/GO/S.O. -- (ZEB) TRIPS 'Y' SHORT
6. 200-300 JET 'X' SLANT/OM/TH/ -- FB WEST SLOT 'F' STRONG
SM/SL/SLUGGO STOP
7. 2-3 JET SCAT HB OPTION -- DBL WING SWITCH

PLAY PASSES:

8. FOX 2-3 'Z' CORNER -- BROWN 'Y' OUTSIDE

MOVEMENT PASSES:

9. P. 97 SOLID SEATTLE -- (T) SOLO LEFT

SCREEN PASSES:

10. S-1 -- RED RIGHT

RUNS:

1. 30-31 PULL TRAP -- RED / RED SLOT
2. 16-17 POWER -- RED / RED SLOT
3. HB 40-41 -- BLUE ('Y' MOTION)
4. 68-69 H.O. -- (T) SOLO / (EAG) SPREAD
5. 68-69 H.O. SOLID -- BLUE / (T) SOLO SLOT /
-- (ZEB) TRIPS
6. 98-99 H.O. SOLID -- GREEN / GREEN SLOT

RED RIGHT
20 BINGO CROSS

BASE

RED RIGHT 'Z' RIGHT
20 BINGO CROSS

(4)

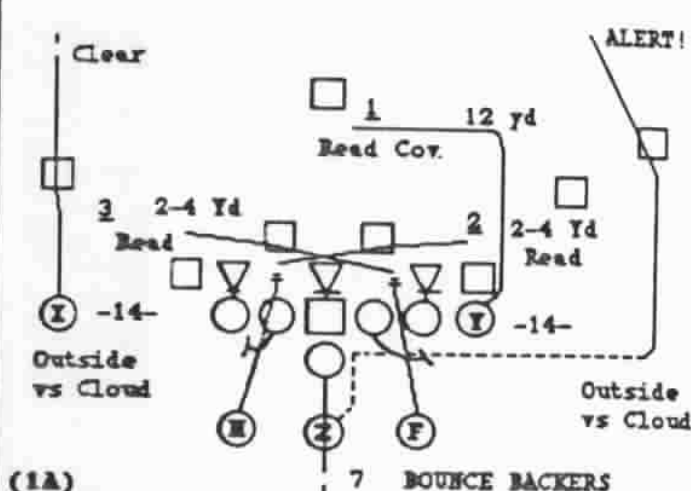
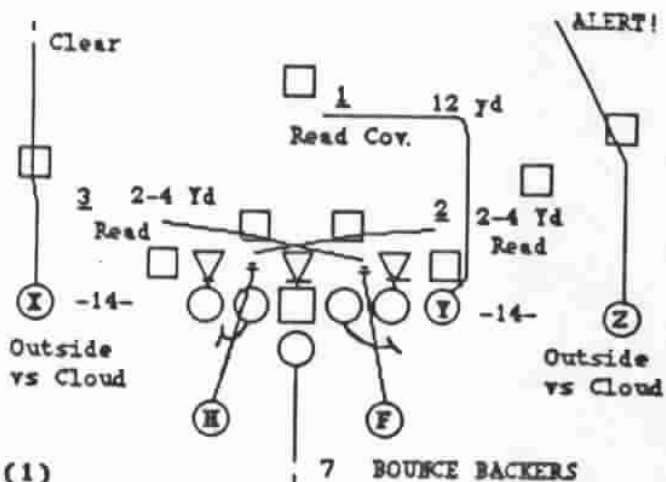

BROWN RIGHT 'B' RIGHT
22 'Y' STICK

FB WEST RIGHT 'FB' COUNTER MOTION
22 SEATTLE

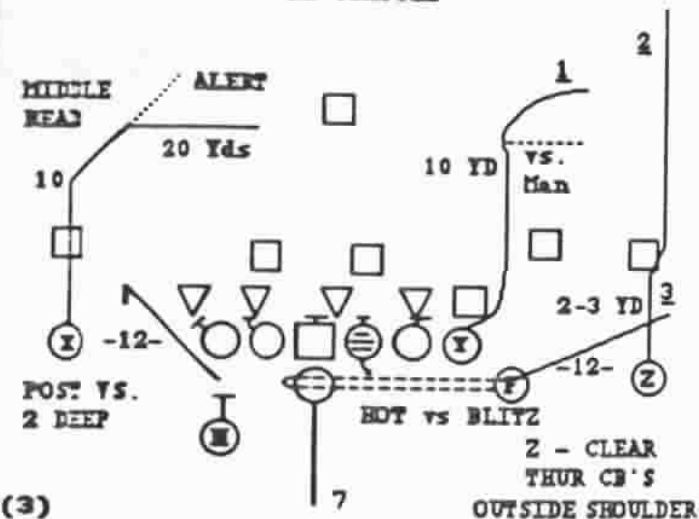
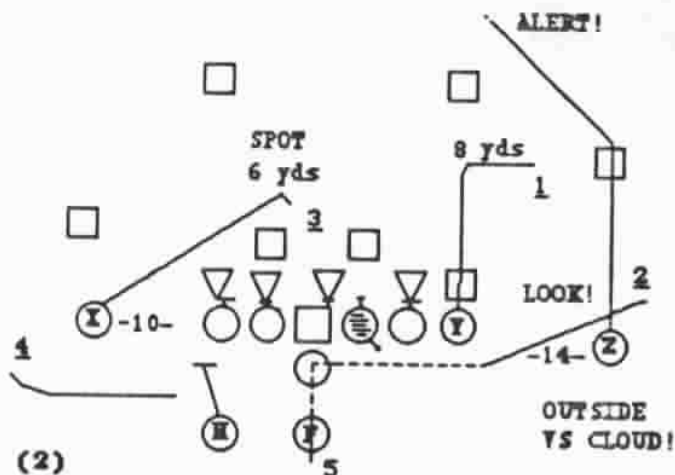

(T) EAST RIGHT SLOT 'U' COUNTER MOTION
50 'X' SPOT

(ZB) TRIPS LEFT 'Y' SHORT
75 DOUBLE CB/DIG/GO

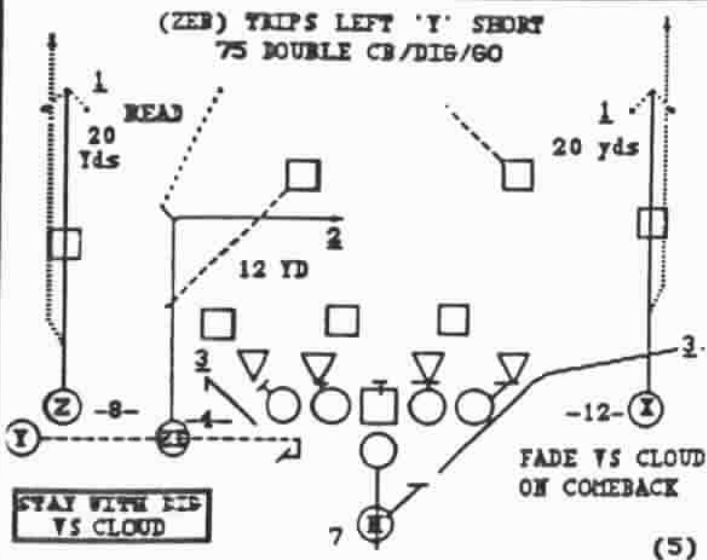
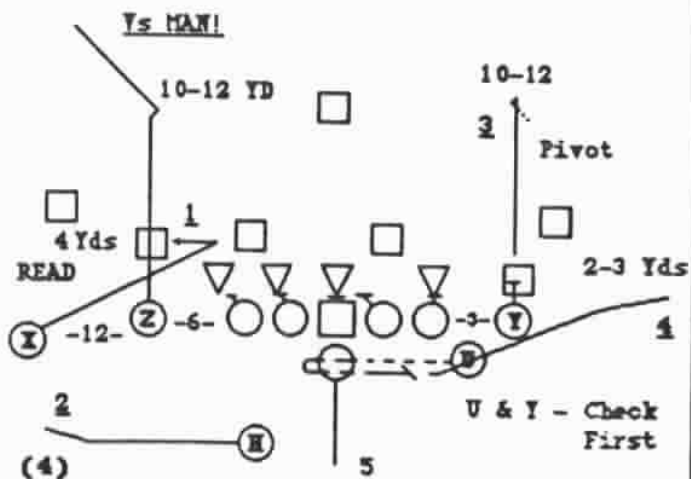

49

30-31 PULL TRAP

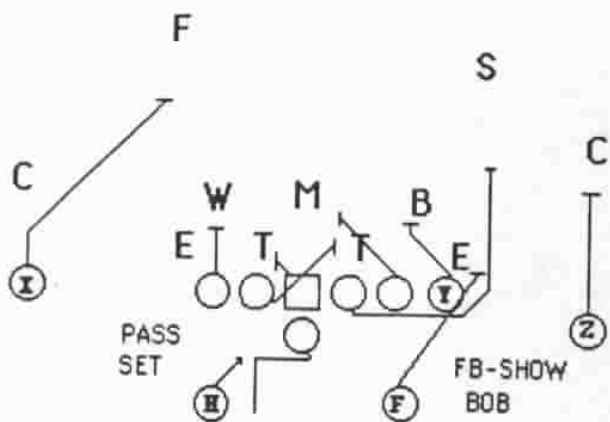

RED RIGHT 30 PULL TRAP

43

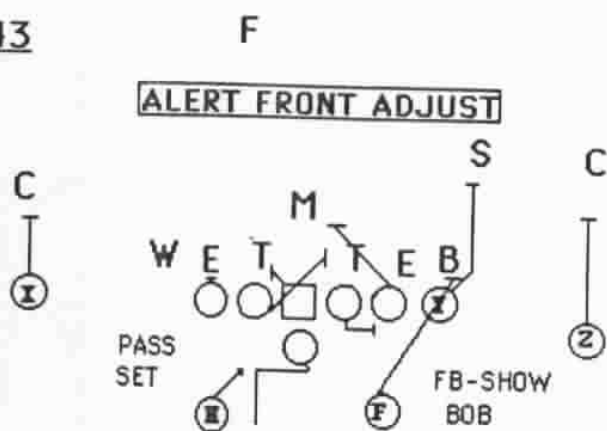

RED RIGHT 30 PULL TRAP

35 (25)

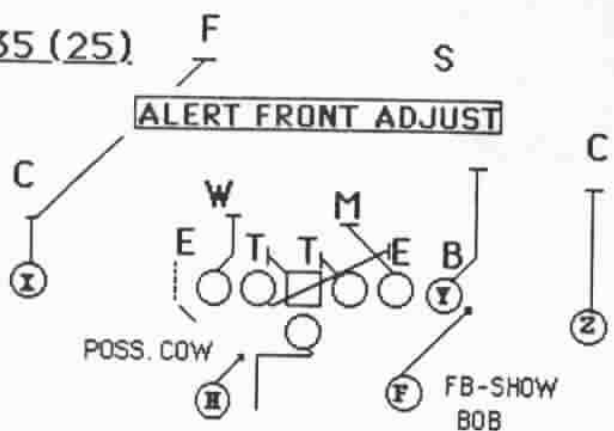

RED RIGHT 30 PULL TRAP

37 (57)

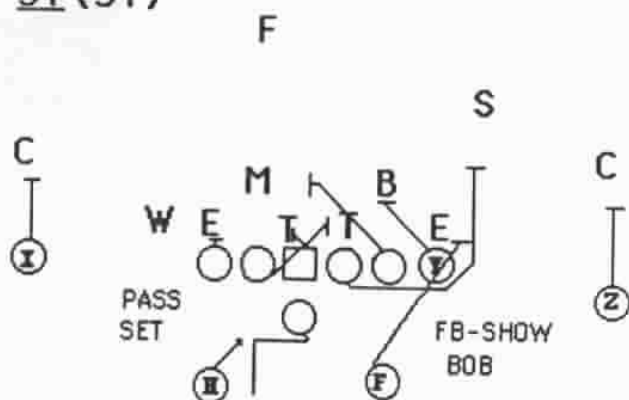

RED RIGHT 30 PULL TRAP

59

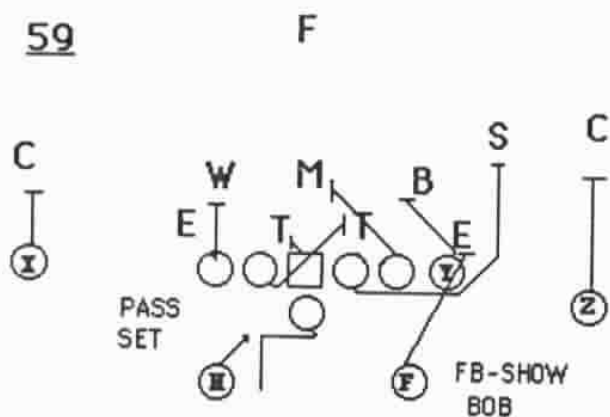

RED RIGHT 30 PULL TRAP

42

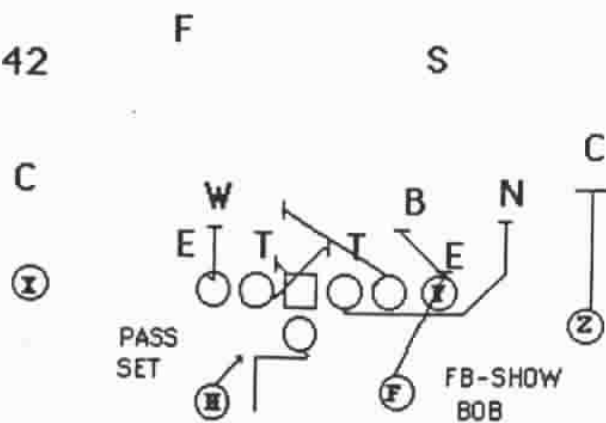

RED RIGHT 30 PULL TRAP

16-17 POWER

49

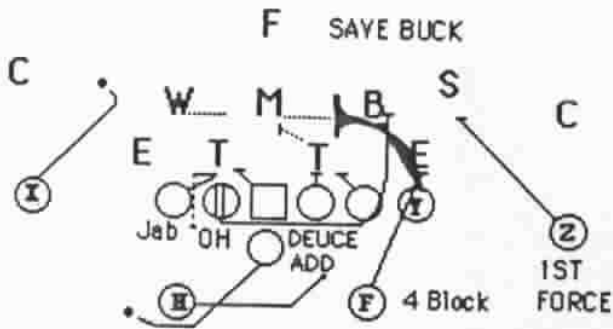

RED RT 16 POWER

43

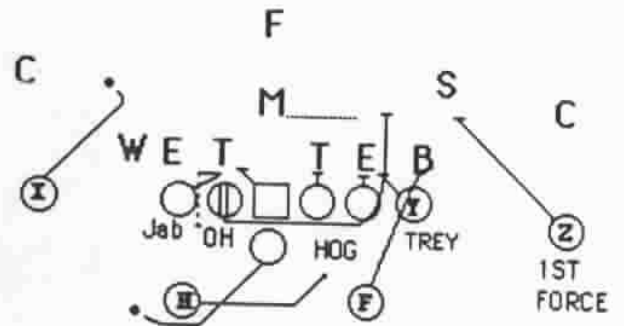

RED RT 16 POWER

25 (35)

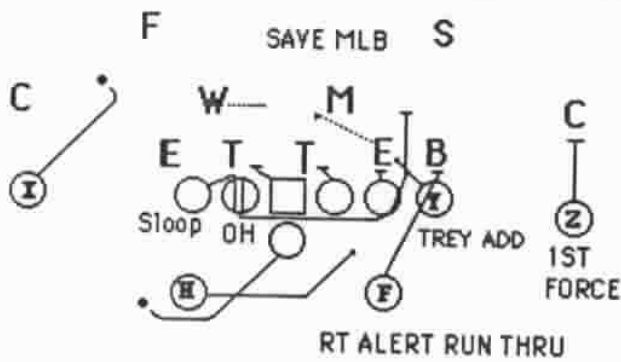

RED RT 16 POWER

57 (37)

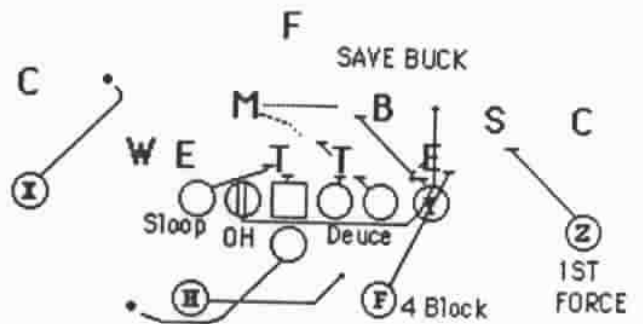

RED RT 16 POWER

59

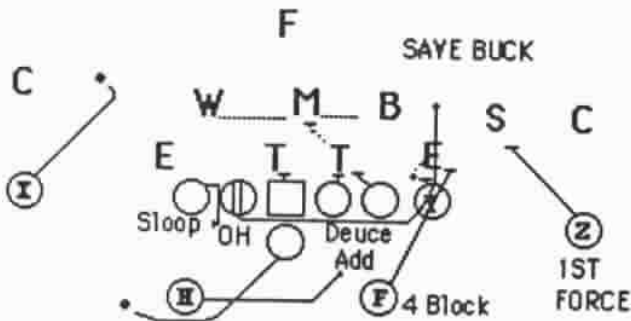

RED RT 16 POWER

42

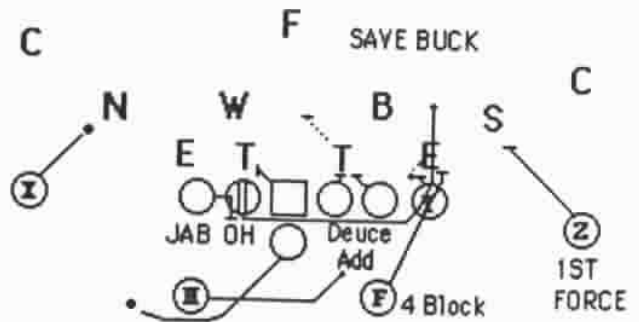

RED RT 16 POWER

HB 40/41

49

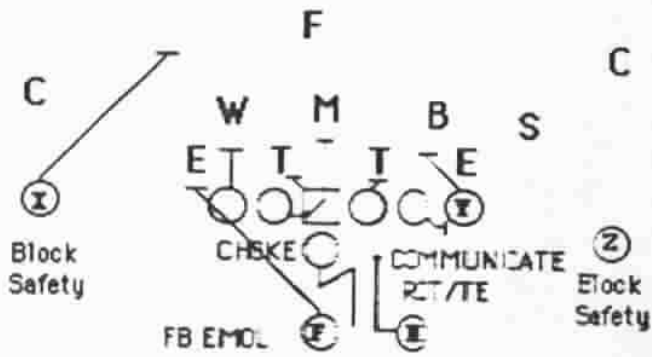

BLUE RIGHT HB 40

43

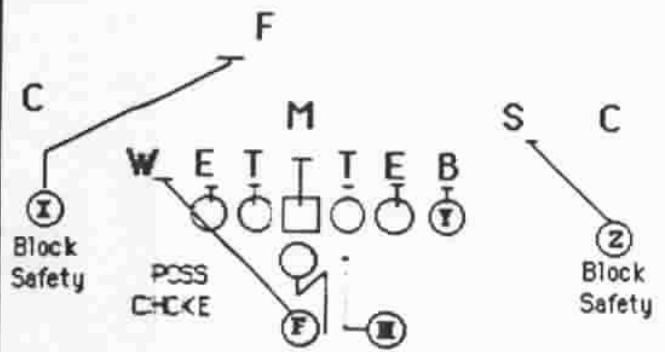

BLUE RIGHT HB 40

25(35)

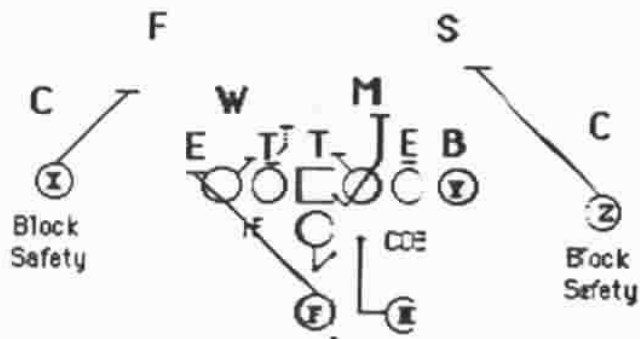

BLUE RIGHT HB 40

57(37)

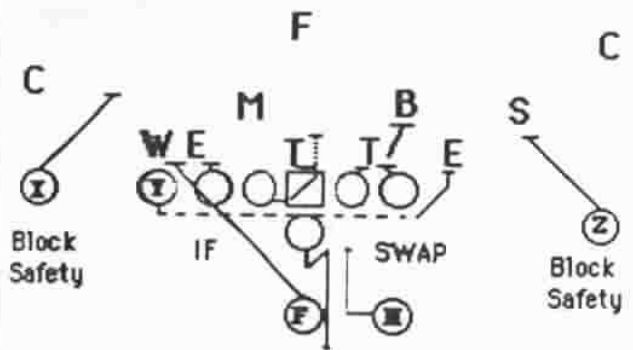

BLUE RIGHT 'Y' MOTION HB 40

59

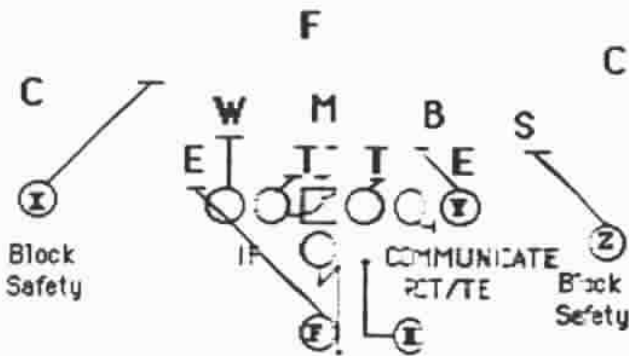

BLUE RIGHT HB 40

42

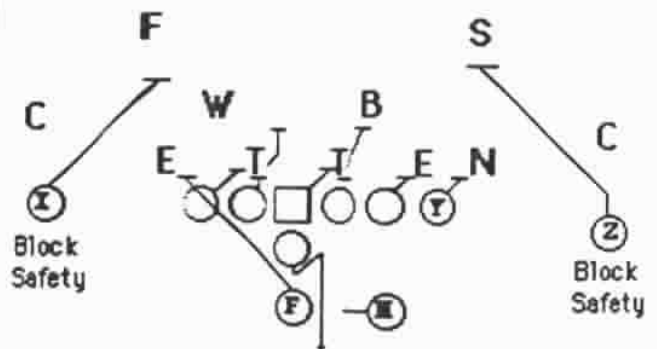

BLUE RIGHT HB 40

68-69 HO (SOLID)

34

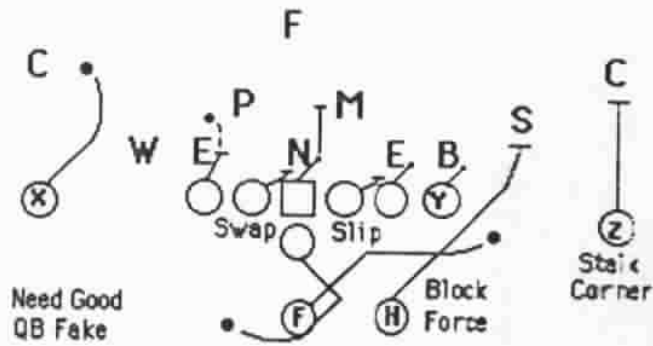

BLUE RIGHT 68 HO SOLID

43

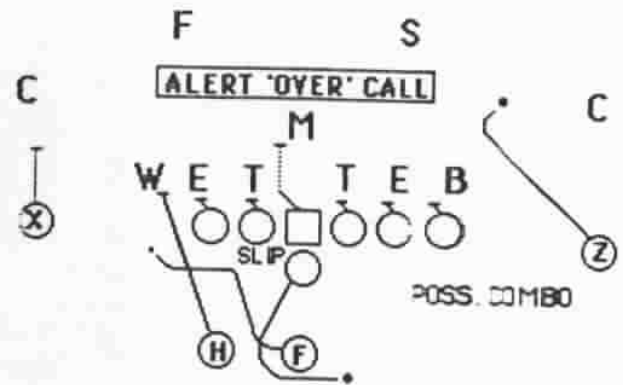

BROWN RIGHT 69 HO (WK)

25 (35)

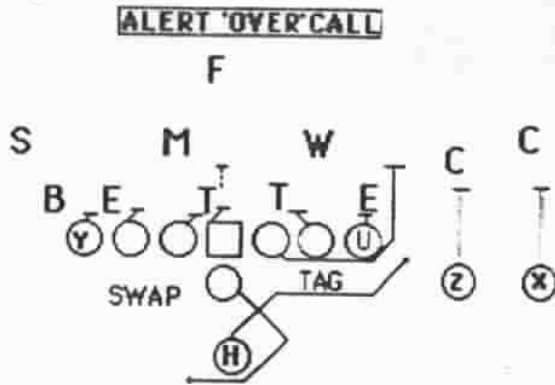

(T) SOLO LEFT SLOT 68 'HO' SOLID

57 (37)

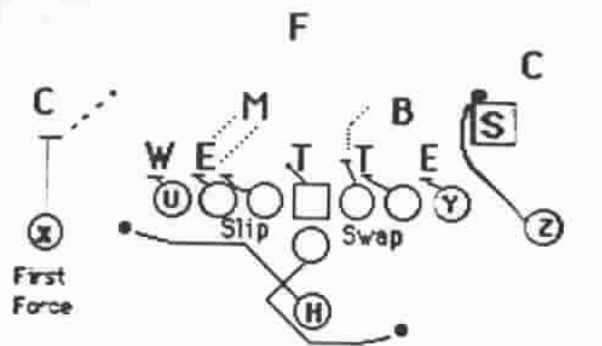

(T) SOLO RIGHT 68 HO ('OVER' CALL)

41 KING

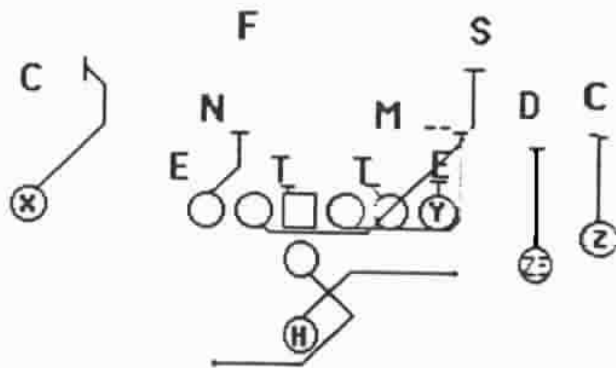

(ZEB) TRIPS RIGHT 68 'HO' SOLID

41

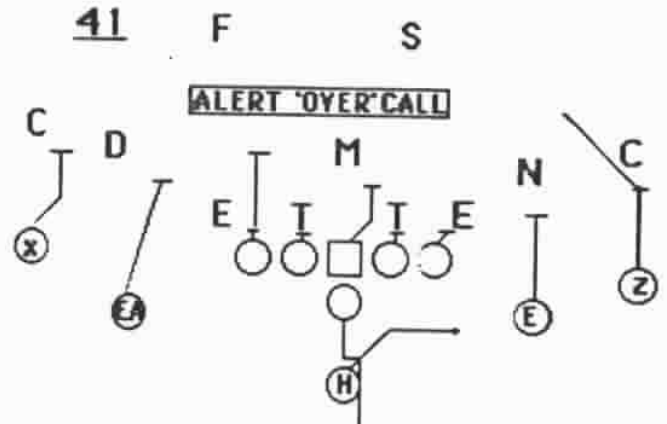

(EAG) SPREAD RIGHT '68' HO

98-99 'HO' SOLID

49

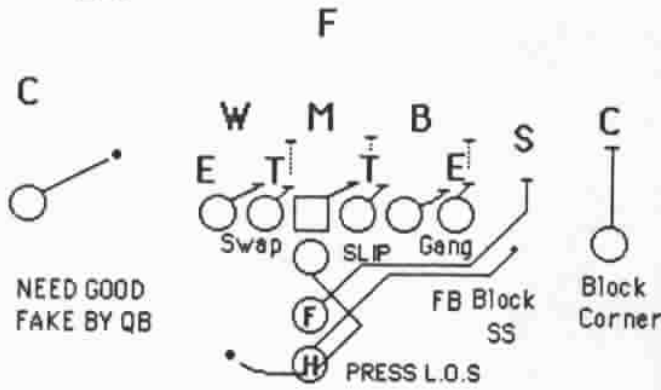

GREEN RIGHT 98 'HO' SOLID

43

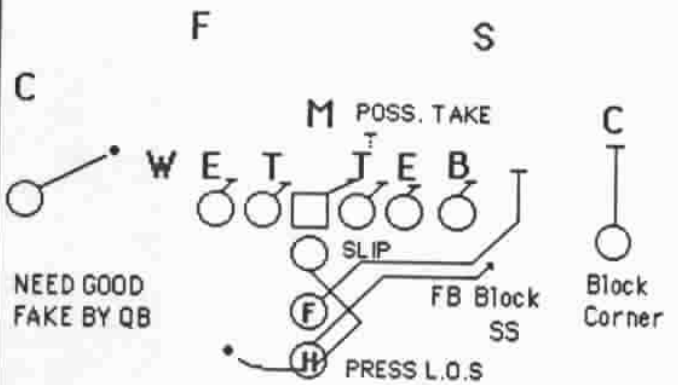

GREEN RIGHT 98 'HO' SOLID

25 (35)

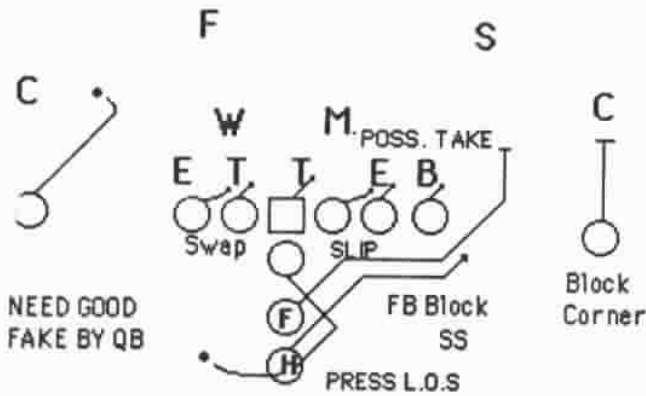

GREEN RIGHT 98 'HO' SOLID

57 (37)

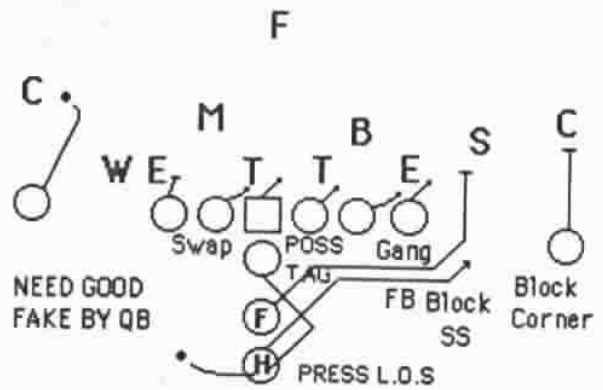

GREEN RIGHT 98 'HO' SOLID

59

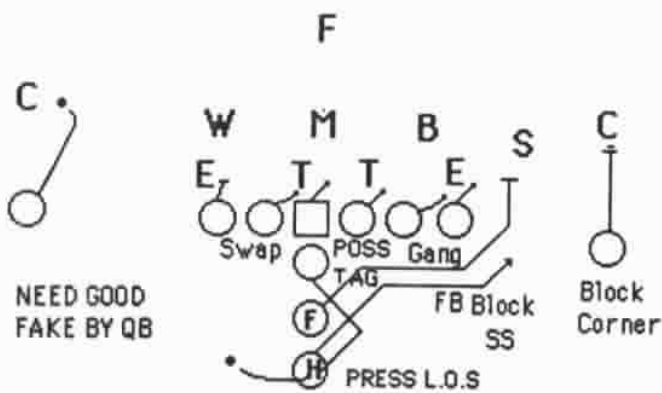

GREEN RIGHT 98 'HO' SOLID

42

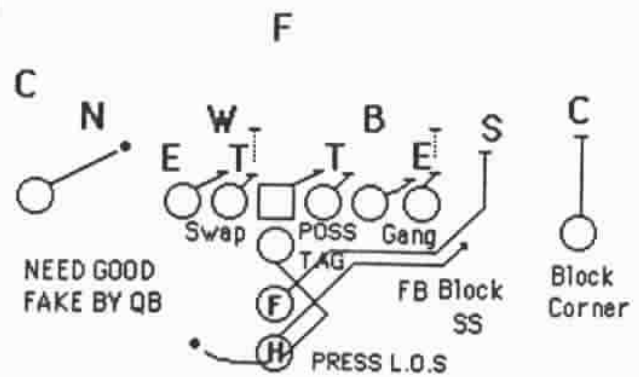

GREEN RIGHT 98 'HO' SOLID

Mini Camp - DAY 3

BASE PASSES:

1. 22-23 (SCAT) TEXAS -- RED 'Y' SHIFT
-- HB WEST 'HB' WEAK
2. 72-73 'X' SHALLOW CROSS -- DBL WING SWITCH
3. 200-300 JET LION/SLUGGO/
DRAGON -- DBL WING FLEX

PLAY PASSES:

4. FOX 2-3 'X-Z' HOOK -- BROWN 'Y' OUTSIDE

MOVEMENT PASSES:

5. FK. 69 QB KP PASS RIGHT -- (T) SOLO LEFT
-- (T) SOLO LEFT SLOT

SCREEN PASSES:

6. P. FB @ 0 'X' SLIP SCREEN LT. -- (T) WEST RIGHT SLOT 'U' LEFT

NICKEL PASSES:

7. 20-21 'Z' CROSS HB FAN -- (E) RED OPEN 'F' WEAK
8. 200-300 JET LION / SLUGGO -- (EAG) SPREAD
9. 2-3 JET SCAT FB OPTION -- (E) DBL WING
10. 2-3 JET 'X' DAGGER -- (ZEB) FAR WEST SLOT
11. 2-3 JET SEATTLE -- (ZEB) DBL WING 'ZEB' STRONG
12. 2-3 JET DBL CROSS HB BURST -- (ZEB) TRIPS

RUNS:

1. FB 0-1 -- BROWN / (T) SOLO /
-- (T) WEST SLOT
2. H-2/H-3 SPLIT -- GREEN
3. 30-31 TRAP -- (EAG) SPREAD
4. FOX 2-3 RUN -- BROWN / RED / GREEN
5. FOX 3-2 WEAK -- BLUE ('Y' MOTION) / RED
6. 99-98 H.O. WEAK -- GREEN / GREEN SLOT

'Y' SHIFT TO RED RIGHT
22 TEXAS

BASE

HB WEST RIGHT 'HB' LEFT
22 SCAT TEXAS

(6)

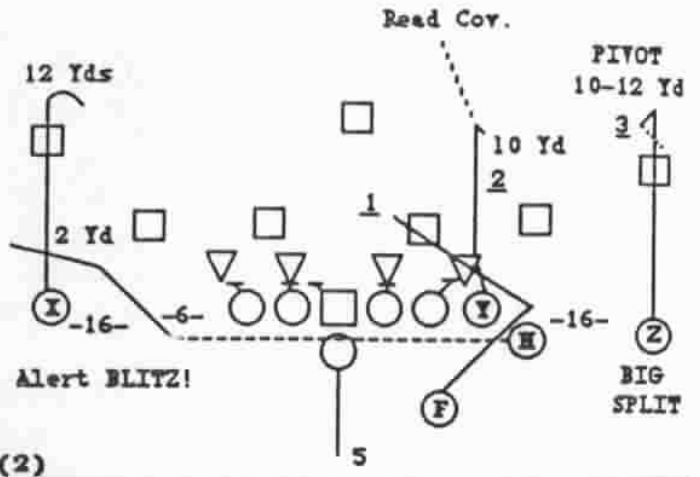
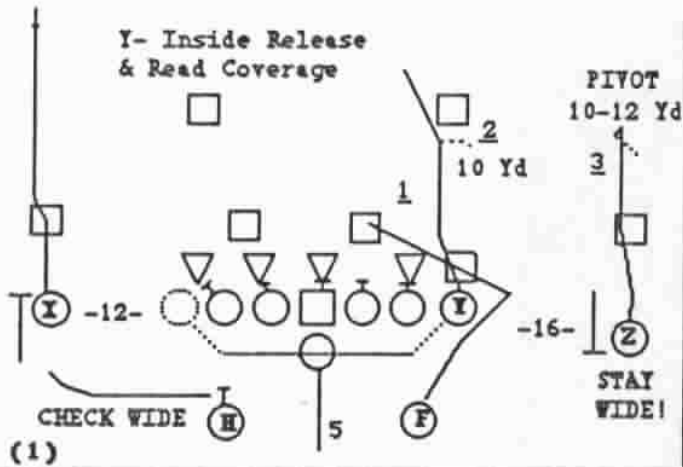

DOUBLE WING RIGHT SWITCH
72 'X' SHALLOW CROSS

DOUBLE WING RIGHT FLEX
200 JET LION / SLUGGO / SLUGGO STOP

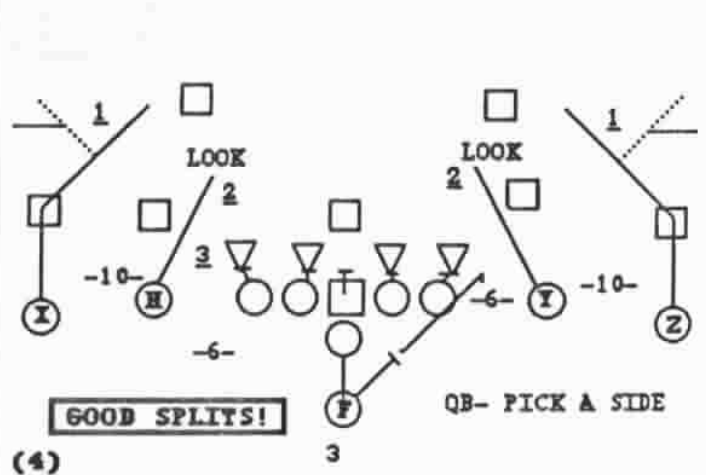
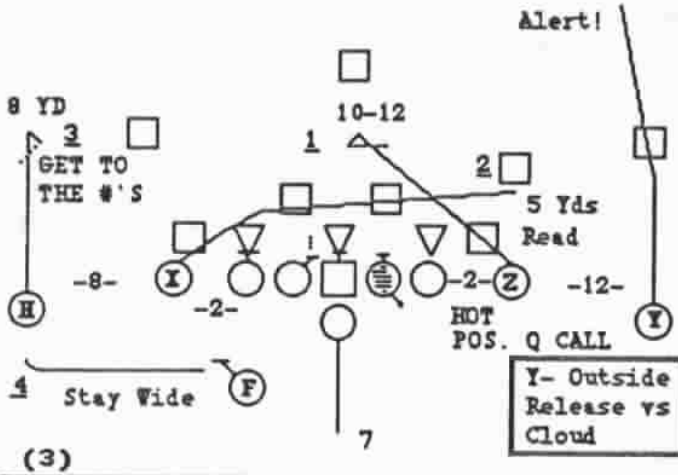

DOUBLE WING RIGHT FLEX
200 JET DRAGON

PLAY PASS

BROWN RIGHT 'Y' OUTSIDE
FOX 2 'Y' 'Z' HOOK

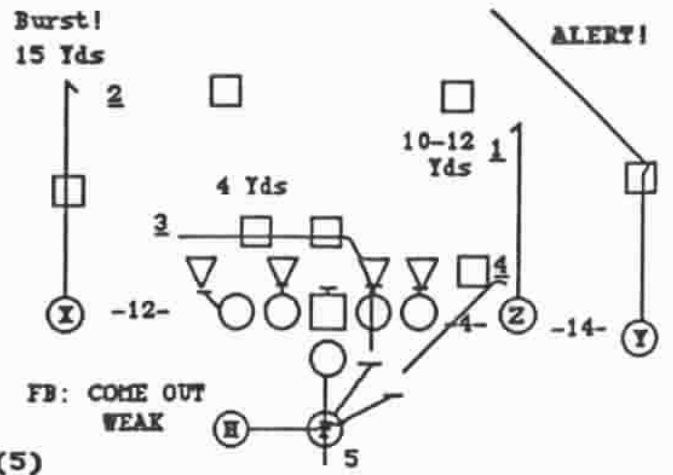
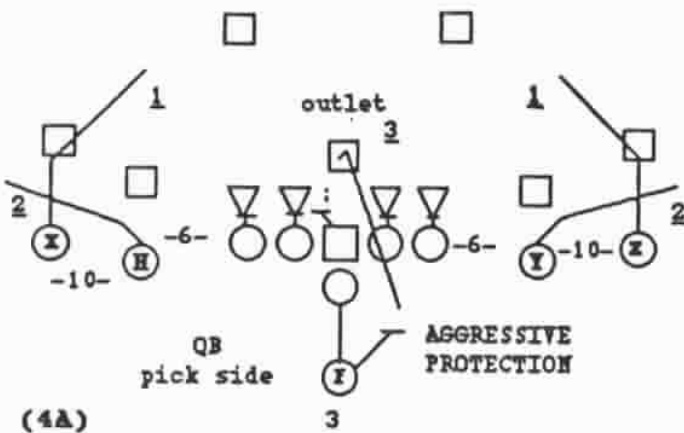

(T) SOLO LEFT
FAKE 69 QB KEEP PASS RIGHT
(POSSIBLE 'OVER')

PLAY PASS

(T) SOLO LEFT SLOT
FAKE 69 QB KEEP PASS RIGHT

(7)

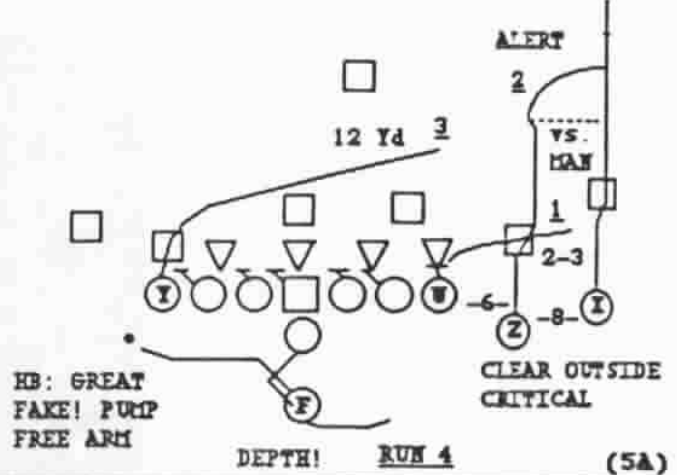
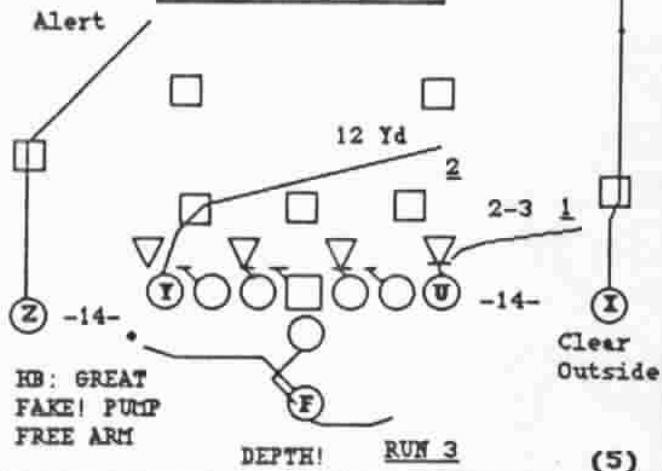

SCREENS

(T) WEST RIGHT SLOT 'U' LEFT
P. FB @ 0 'X' SLIP SCREEN LEFT

NICKEL

(E) RED LEFT OPEN 'F' RIGHT
21 "Z" CROSS HB FAN

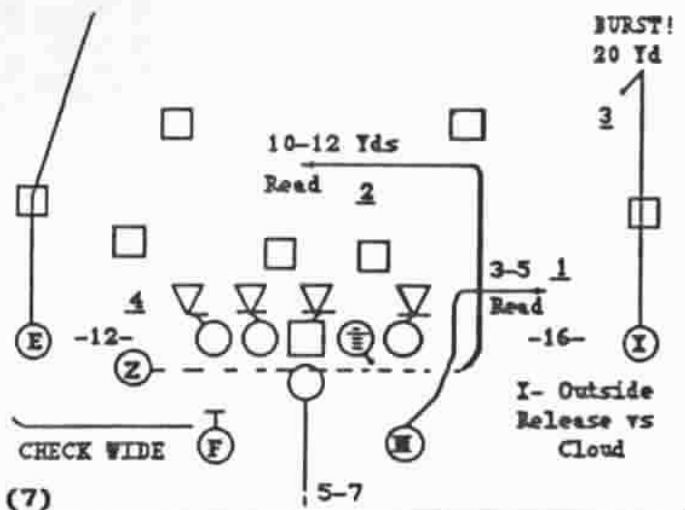
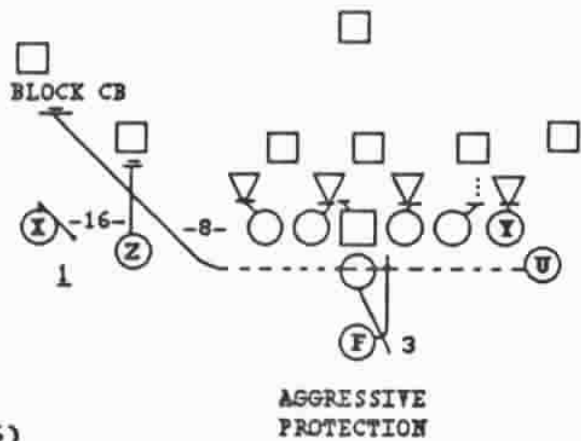

(EAG) SPREAD LEFT
300 JET LION / SLUGGO / SLUGGO STOP

(E) DOUBLE WING RIGHT
2 JET SCAT FB OPTION

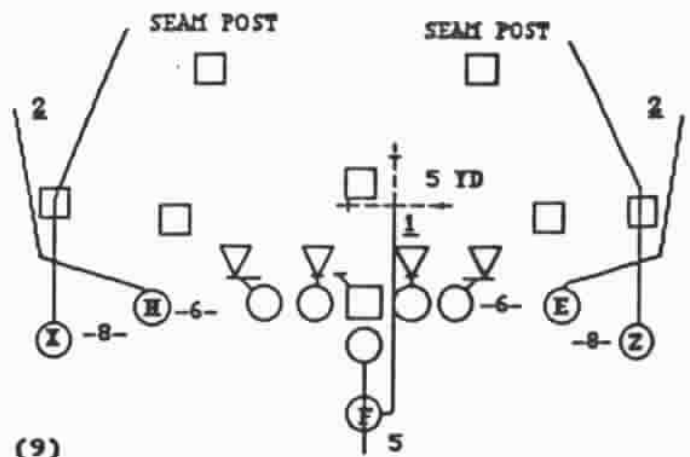
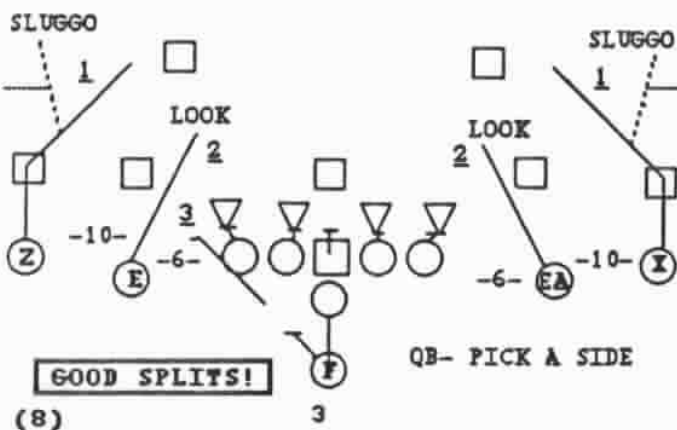

FB @ 0-1

34



BROWN RT FB @ 0

49

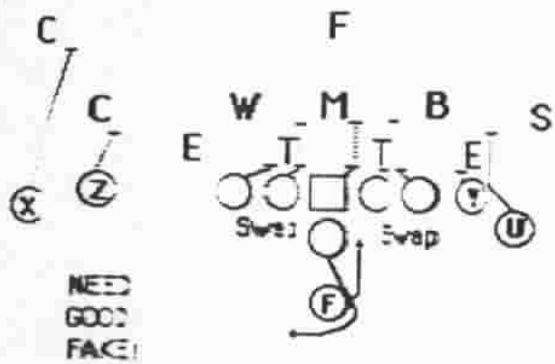

(T) WEST RIGHT SLOT FB @ 0

25 (35)

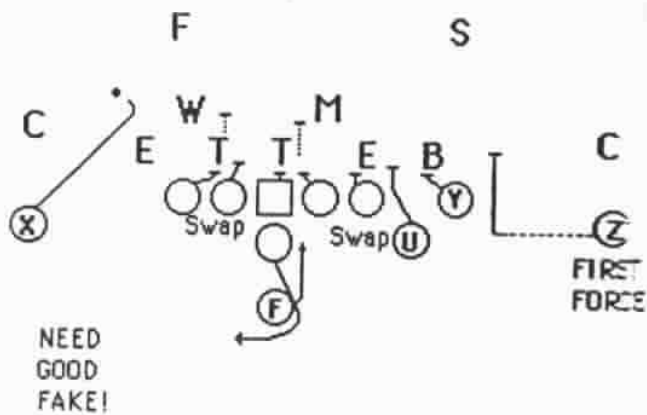

(T) EAST RIGHT 'F' SHORT FB @ 0

57 (37)

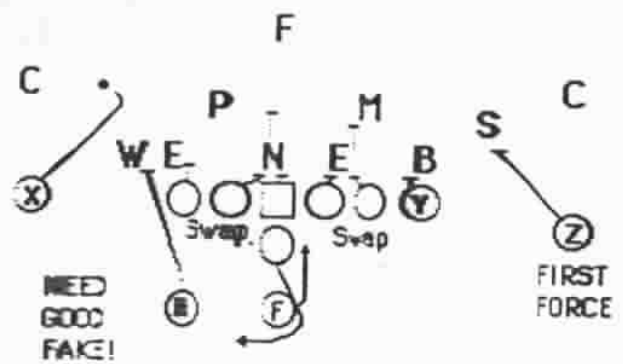

BROWN RT FB @ 0

59

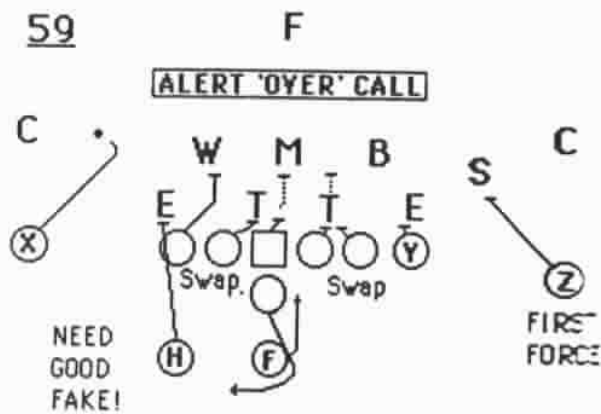

BROWN RT FB @ 0

42

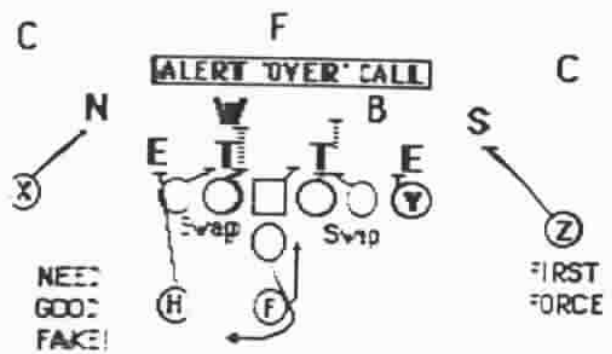

BROWN RT FB @ 0

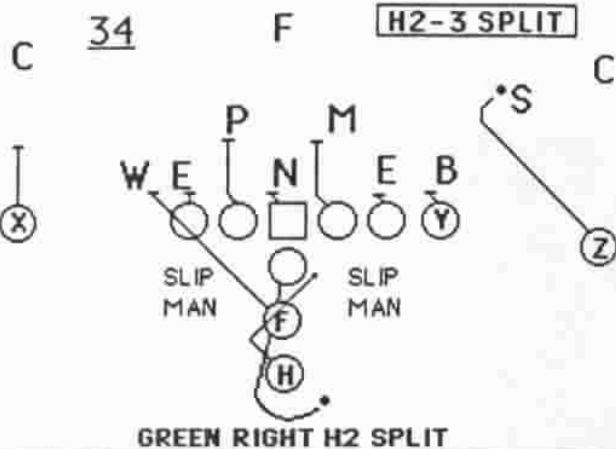

GREEN RIGHT H2 SPLIT

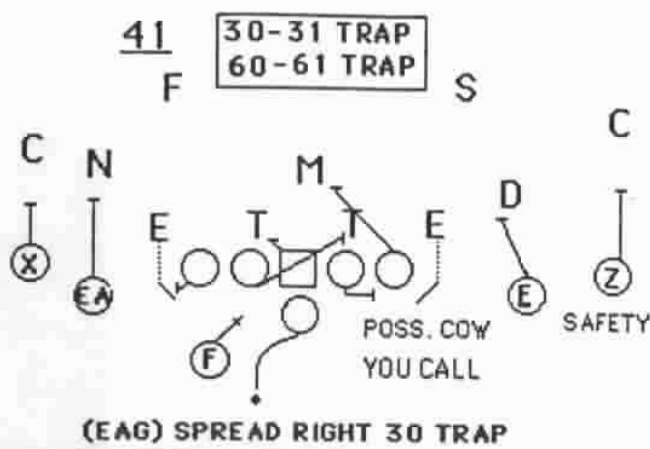

(EAG) SPREAD RIGHT 30 TRAP

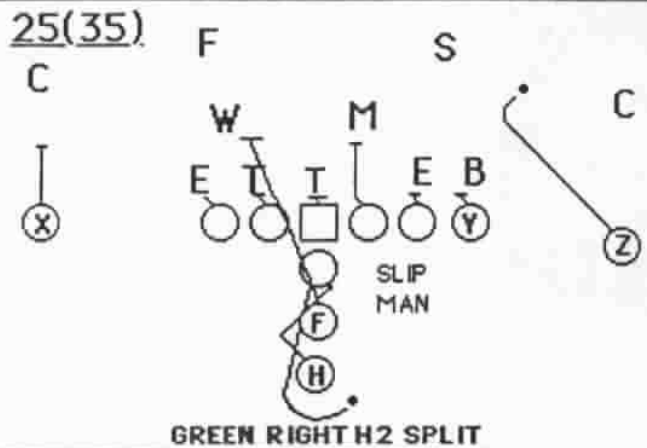

GREEN RIGHT H2 SPLIT

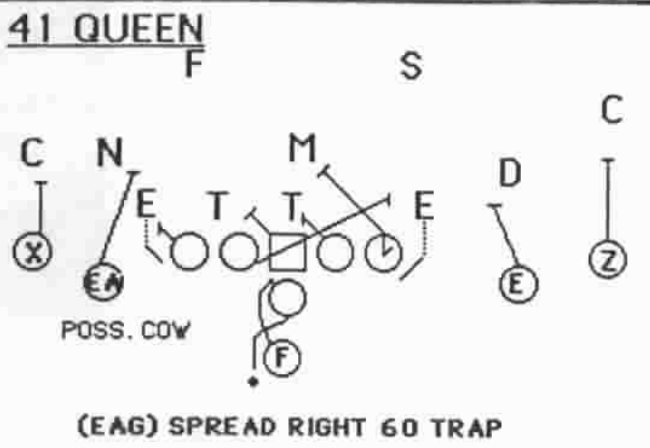

(EAG) SPREAD RIGHT 60 TRAP

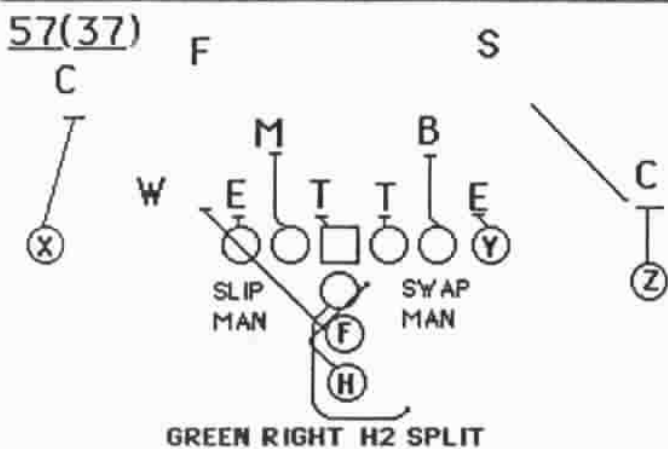

GREEN RIGHT H2 SPLIT



(EAG) SPREAD RIGHT 30 TRAP

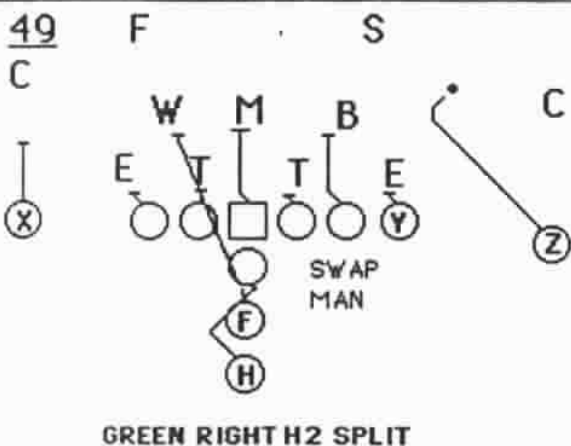

GREEN RIGHT H2 SPLIT

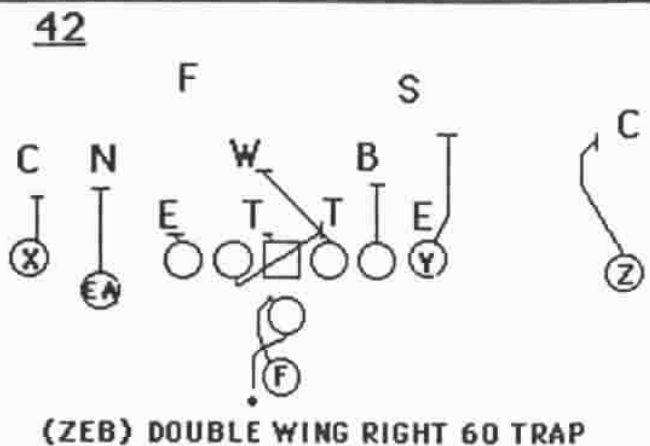

(ZEB) DOUBLE WING RIGHT 60 TRAP

FOX 2-3 RUN

49

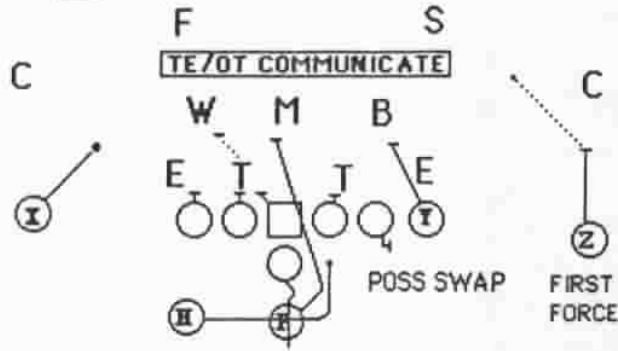

BROWN RIGHT FOX 2 RUN

43

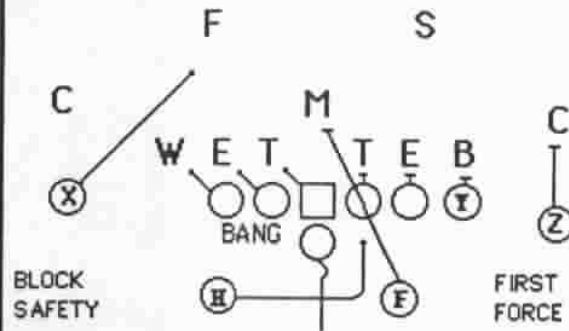

RED RIGHT FOX 2 RUN

25 (35)

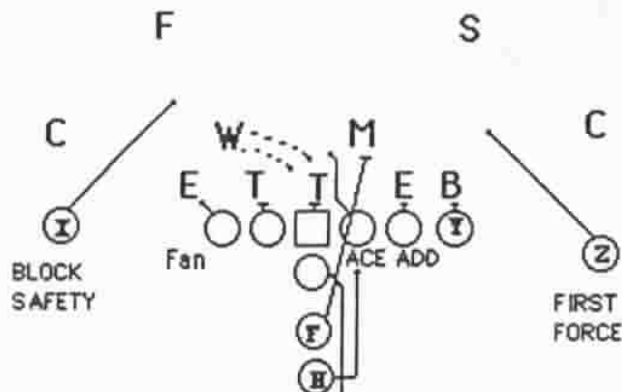

GREEN RIGHT FOX 2 RUN

57 (37)

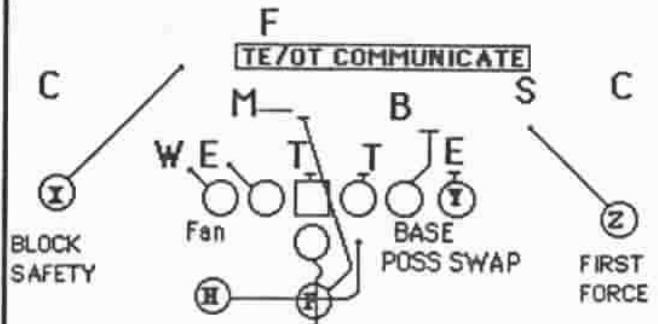

BROWN RIGHT FOX 2 RUN

59

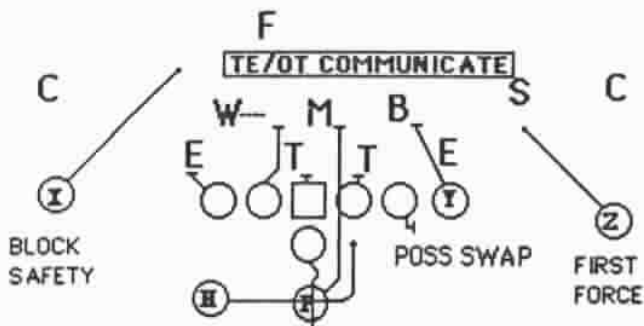

BROWN RIGHT FOX 2 RUN

42

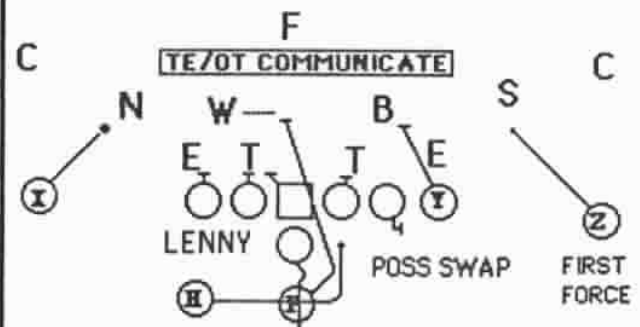

BROWN RIGHT FOX 2 RUN

FOX 2-3 RUN

49

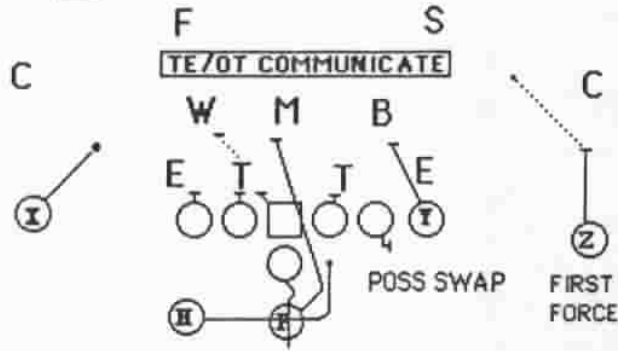

BROWN RIGHT FOX 2 RUN

43

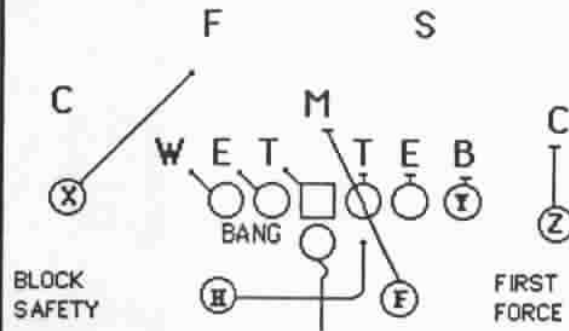

RED RIGHT FOX 2 RUN

25 (35)

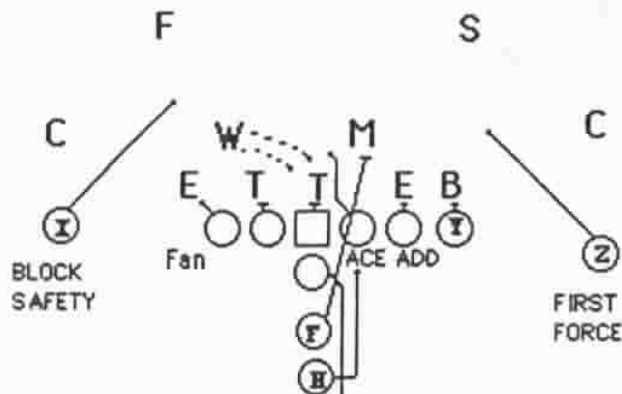

GREEN RIGHT FOX 2 RUN

57 (37)

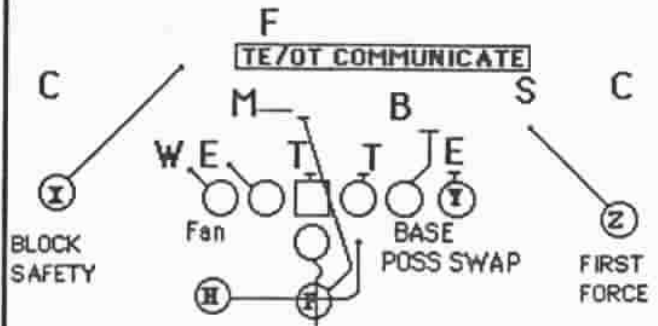

BROWN RIGHT FOX 2 RUN

59

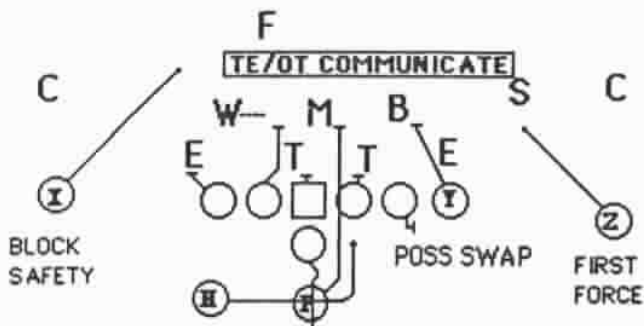

BROWN RIGHT FOX 2 RUN

42

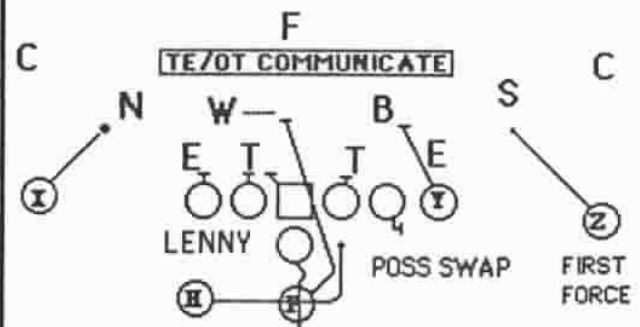

BROWN RIGHT FOX 2 RUN

GREEN RIGHT 99-98 HO WK

49

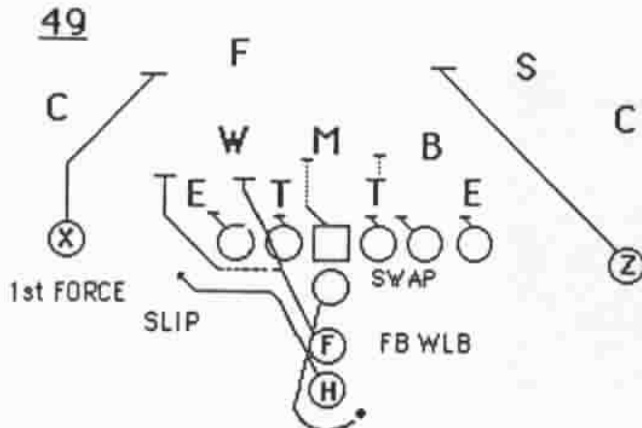

GREEN RIGHT 99 HO WK

43

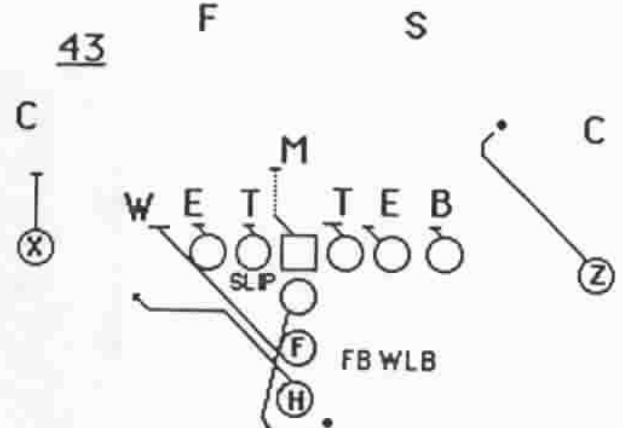

GREEN RIGHT 99 HO WK

25 (35)

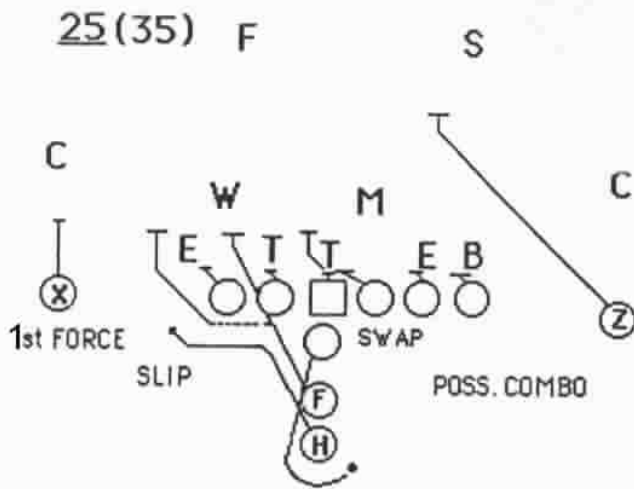

GREEN RIGHT 99 HO WK

57 (37)

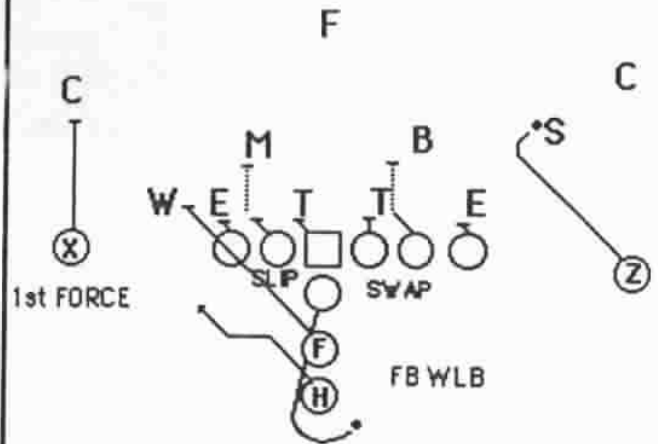

GREEN RIGHT 99 HO WK

59

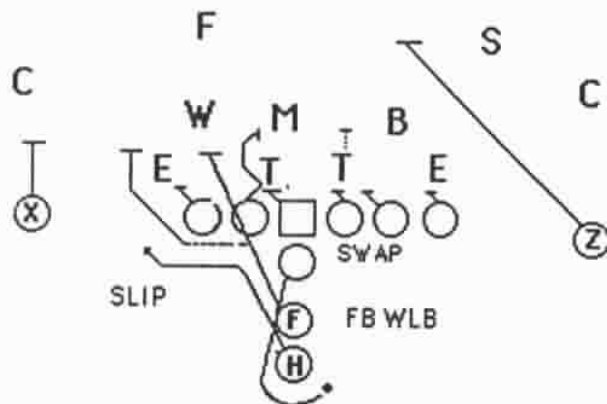

GREEN RIGHT 99 HO WK

Mini Camp - Day 4

BASE PASSES:

1. 22-23 SCAT TEXAS 'Y' CROSS -- HB WEST 'HB' WEAK
2. 24-25 DBL ANGLE BACK -- RED
3. 2-3 JET DINO 'Y' SHALLOW CRS -- HB SHIFT TO FAR WEST SLOT
4. 3 JET RENO 'Z' SWING -- (T) OPEN WEST LT. SLOT 'U'
SHORT

PLAY PASSES:

5. P. 15 BIM HB SEAM -- RED RIGHT

MOVEMENT PASSES:

6. P. 396 'X' OMAHA -- DBL WING LT. SWITCH 'Y'
SHORT

SCREEN PASSES:

7. HB 'G' SCREEN WEAK -- (EAG) SPREAD 'EAG' STRONG

NICKEL PASSES:

8. 2-3 JET DBL ARROW 'EAG' CRS -- (EAG) SPREAD
9. 2-3 JET WINSTON 'E' CROSS -- (EAG) SPREAD
10. 2-3 JET DBL 'Z' -- (EAG) SPREAD SWITCH
11. 2-3 JET ALL GO (FK. FB40) -- (EAG) SPREAD
12. 2-3 JET SCAT 'EAG' OPTION -- (EAG) SPREAD
13. 2-3 JET DIAMOND BACK -- (EAG) TRIPS

NICKEL RUNS:

1. 66-67 T -- (ZEB) DBL WING
2. 67-66 SLANT -- (ZEB) DBL WING
3. 15-14 DRAW -- (ZEB) TRIPS
4. 60-61 TRAP -- (ZEB) DBL WING /
-- (EAG) SPREAD

HB WEST RIGHT 'HB' LEFT
22 SCAT TEXAS 'Y' CROSS

BASE

RED RIGHT
24 DOUBLE ANGLE BACK

(9)

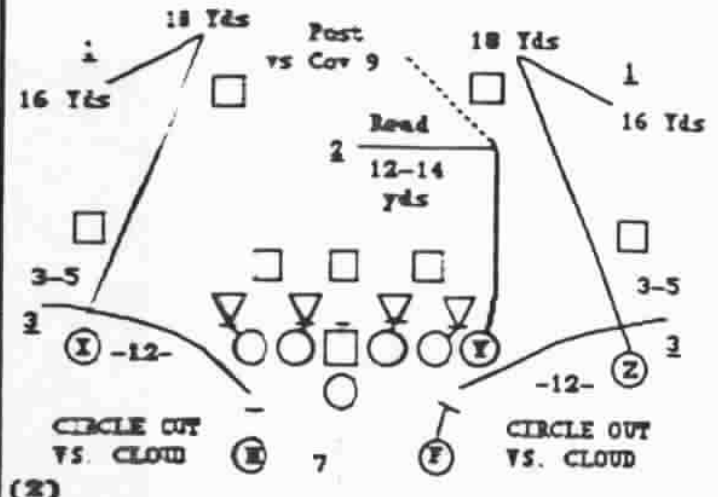
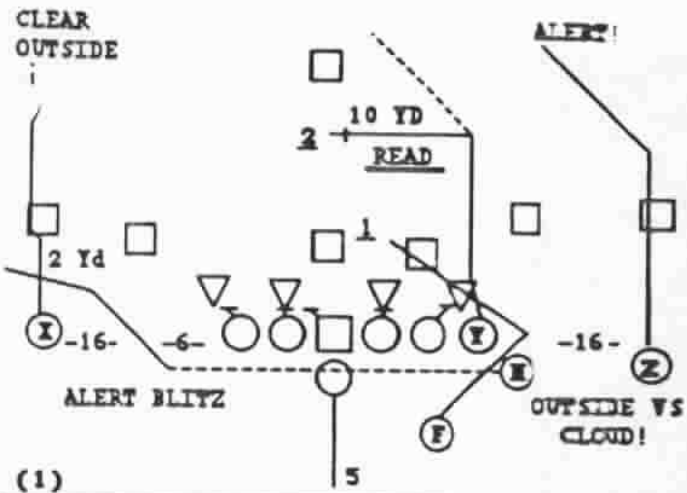

(1)

(2)

HB SHIFT TO FAR WEST LEFT SLOT
3 JET DINO 'Y' SHALLOW CROSS

(Y) OPEN WEST LEFT SLOT 'U' SHORT
3 JET KENO 'Z' SWING

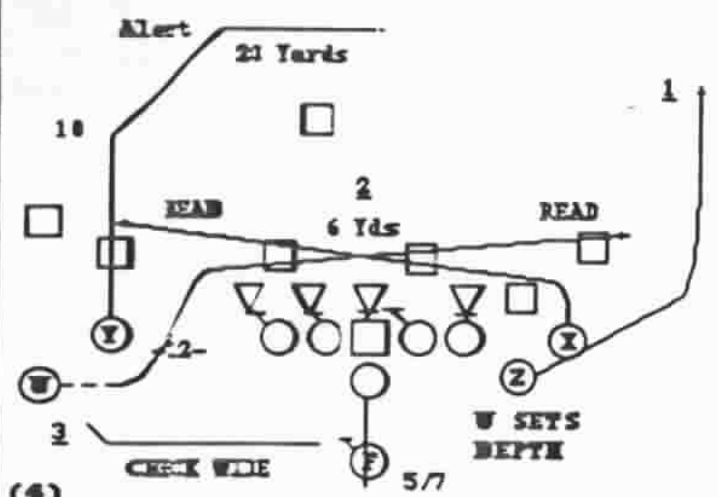
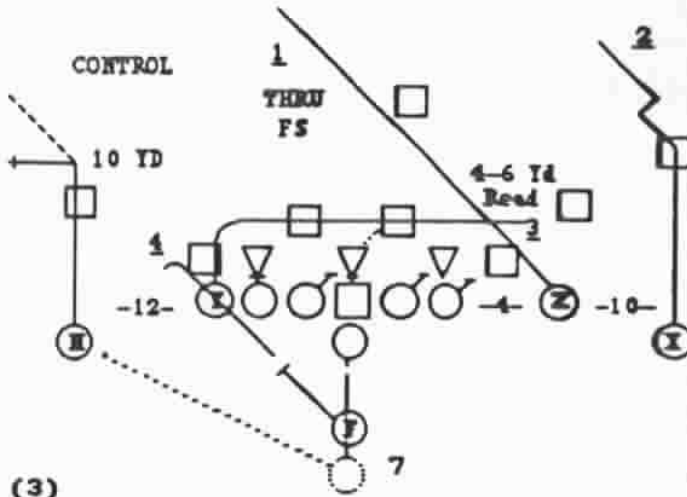

(3)

(4)

PLAY PASS

RED RIGHT
PASS 15 BHM HB SEAM

MOVEMENT

DOUBLE WING LEFT SWITCH 'Y' SHORT
PASS 396 'Y' OGRA

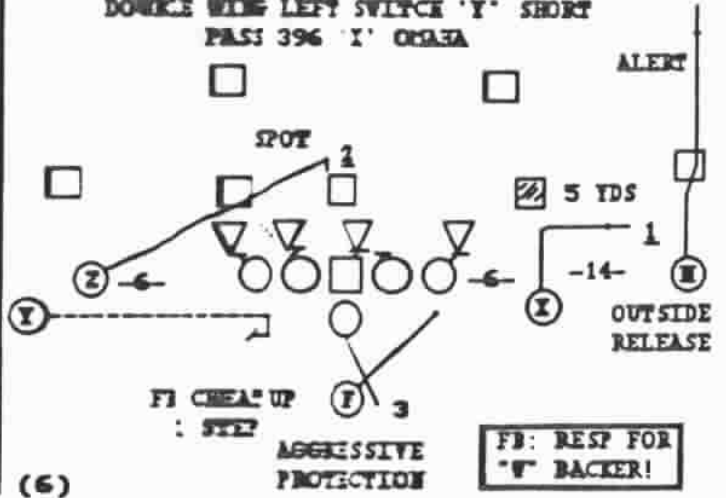
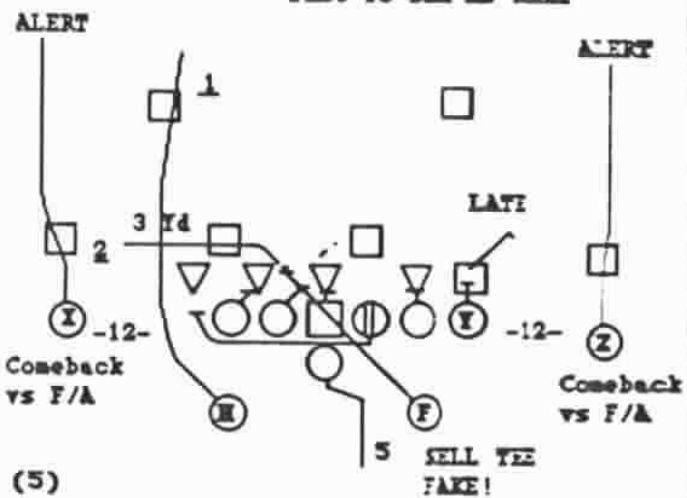

(5)

(6)

FB: REST FOR
'W' BACKER!

SCREENS

(EAG) SPREAD LEFT 'EAG' LEFT
HB 'G' SCREEN RIGHT

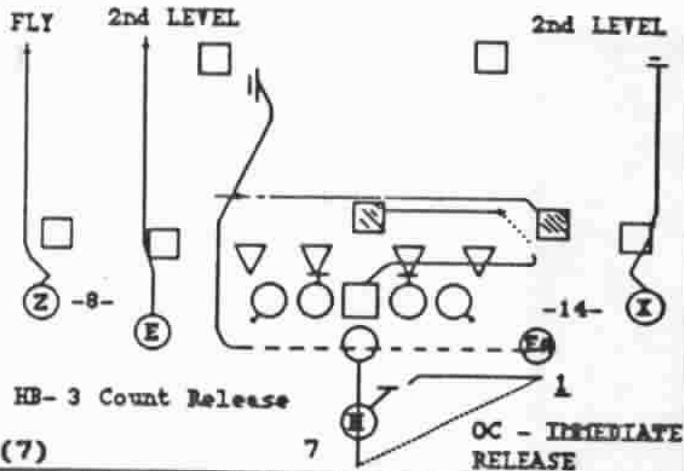

NICKEL

(EAG) SPREAD LEFT (10)
3 JET DOUBLE ARROW 'EAGLE' CROSS

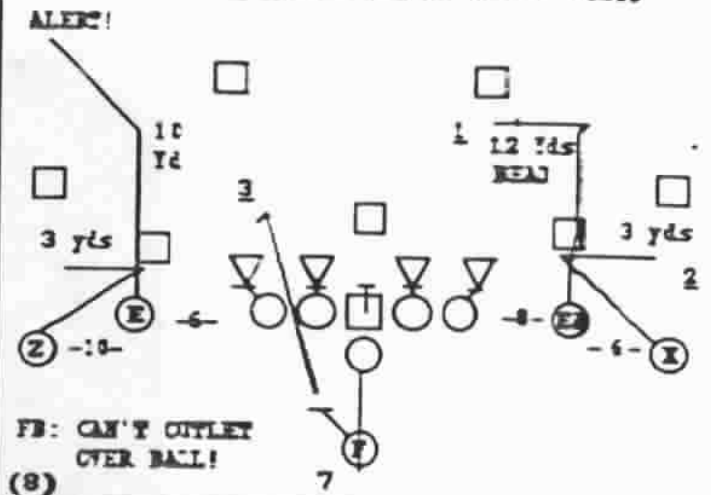

(EAG) SPREAD RIGHT
3 JET WINSTON 'E' CROSS

POSSIBLE 'Z' CALL

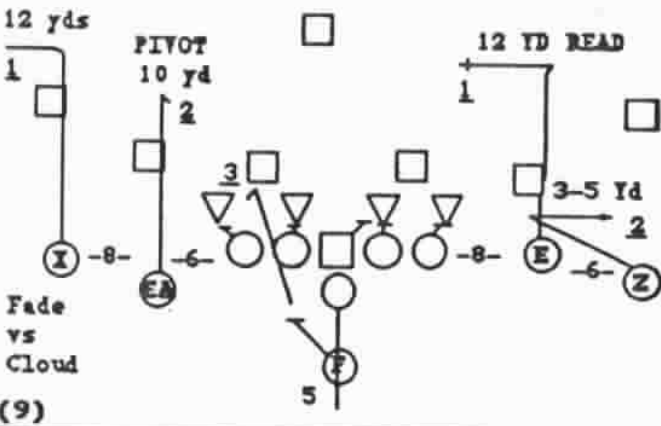

(EAG) SPREAD LEFT
3 JET DOUBLE 'Z'

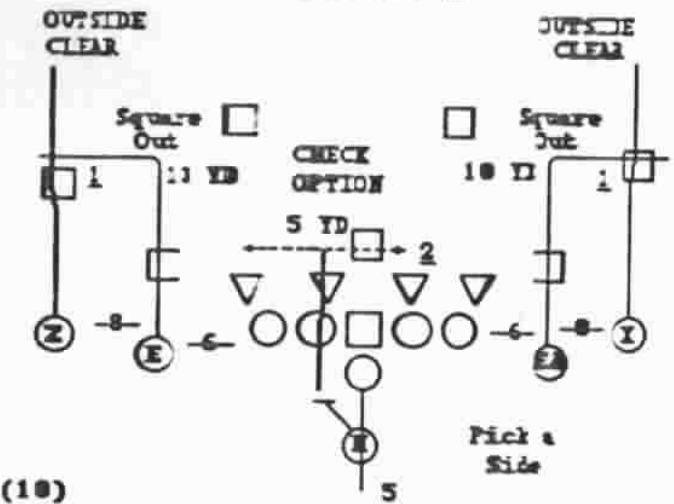

(EAG) SPREAD RIGHT
2 JET ALL GO (FK FB40)

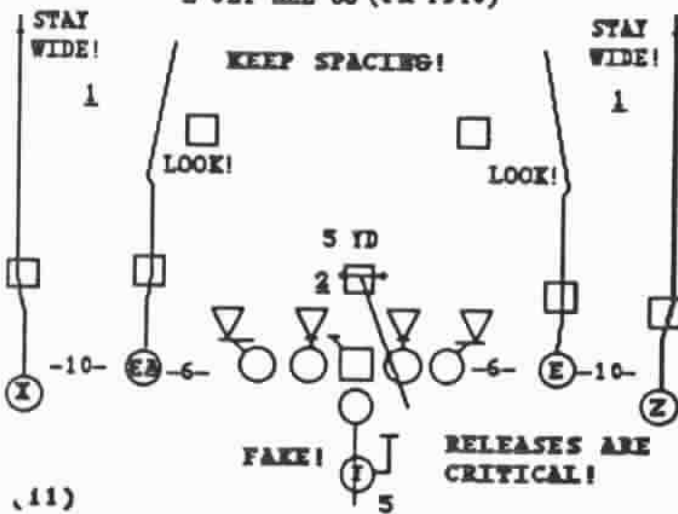

(EAG) SPREAD LEFT
2 JET SCAT 'EAGLE' OPTION

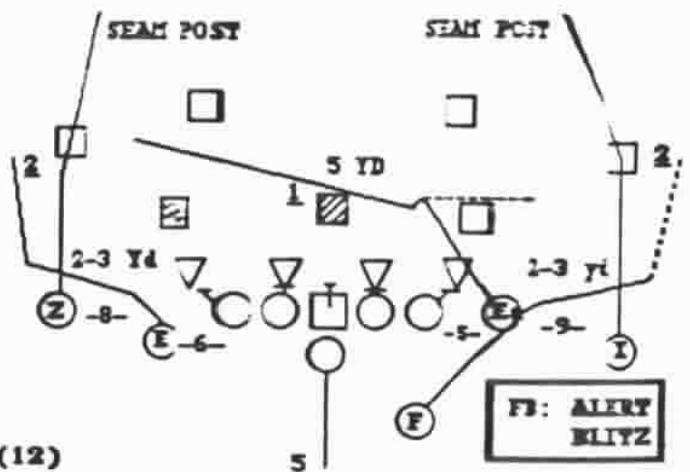

(EAG) TRIPS RIGHT
2 JET DIAMOND BACK

NICKEL

(11)

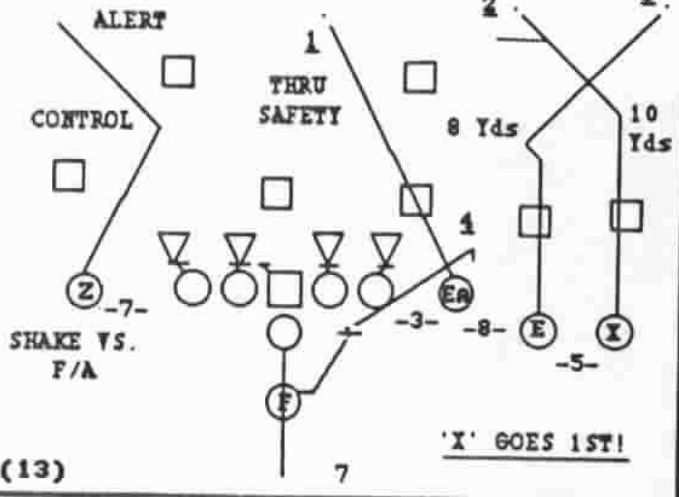

(13)

'X' GOES 1ST!

66-67 'T'

NI RUNS

67-66 SLANT

41 F S

41 F S

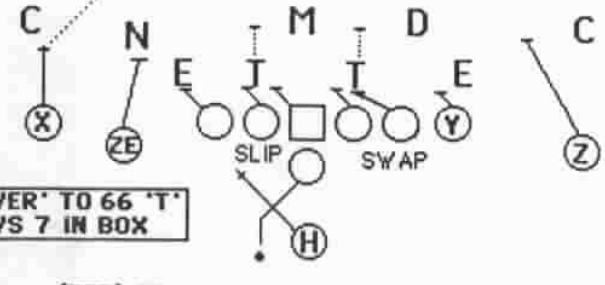
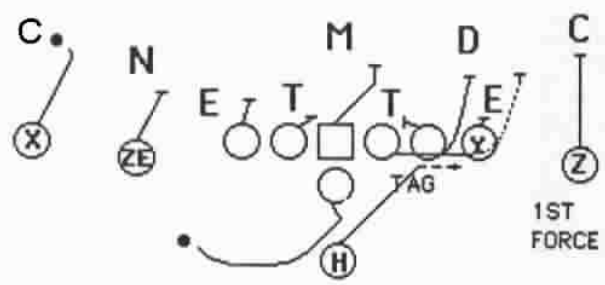

(ZEB) DBL WING RIGHT 66 'T'

(ZEB) DBL WING RIGHT 67 SLANT

41 QUEEN

41 QUEEN

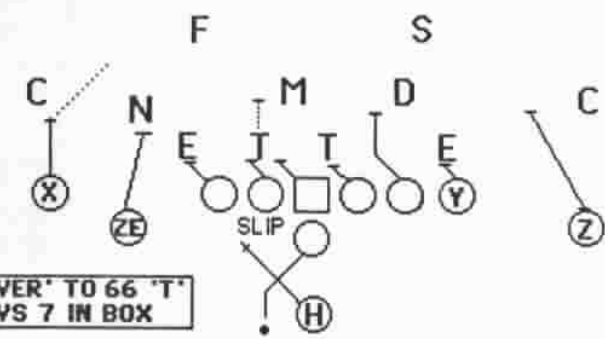
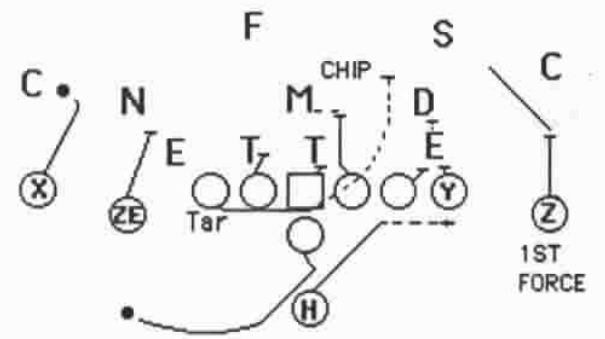

(ZEB) DBL WING RIGHT 66 'T'

(ZEB) DBL WING RIGHT 67 SLANT

41 KING

41 KING

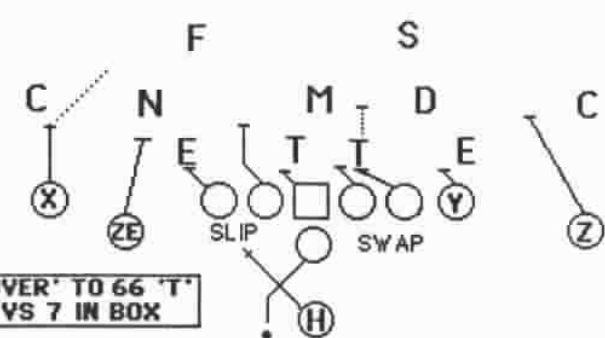
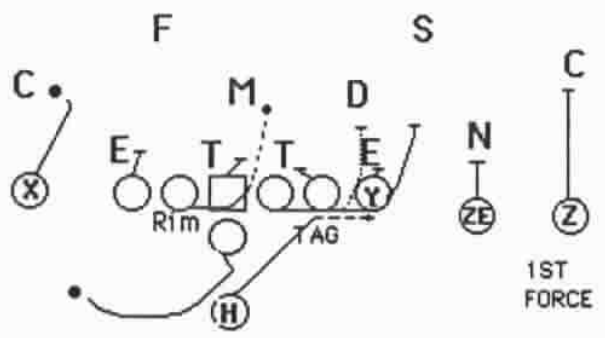

(ZEB) TRIPS RIGHT 66 'T' SOLID

(ZEB) DBL WING RIGHT 67 SLANT

42

42

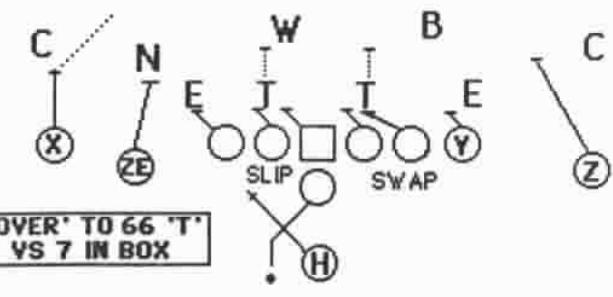
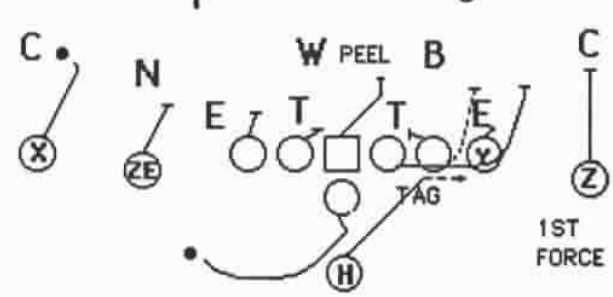

(ZEB) DBL WING RIGHT 66 'T'

(ZEB) DBL WING RIGHT 67 SLANT

42

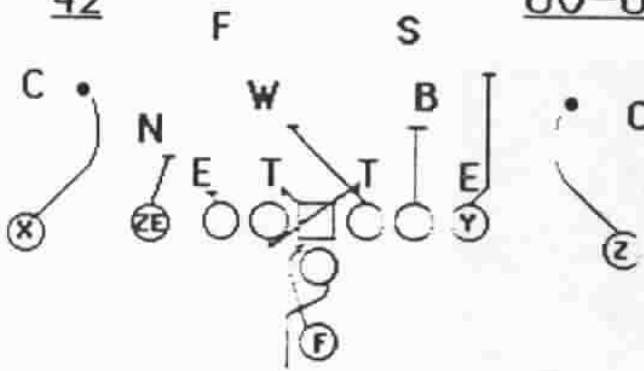

(ZEB) DOUBLE WING RIGHT 60 TRAP

60-61 TRAP

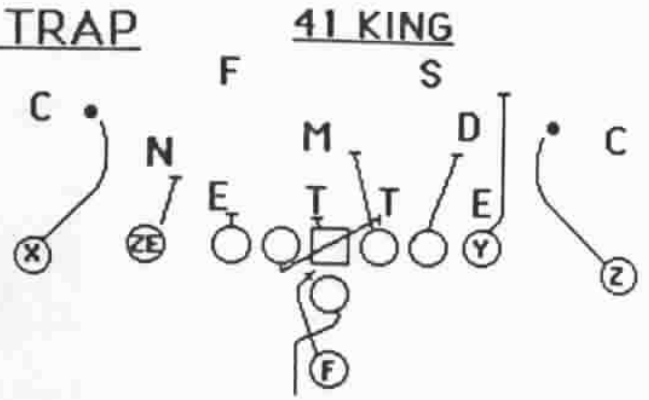

(ZEB) DOUBLE WING RIGHT 60 TRAP

41 QUEEN

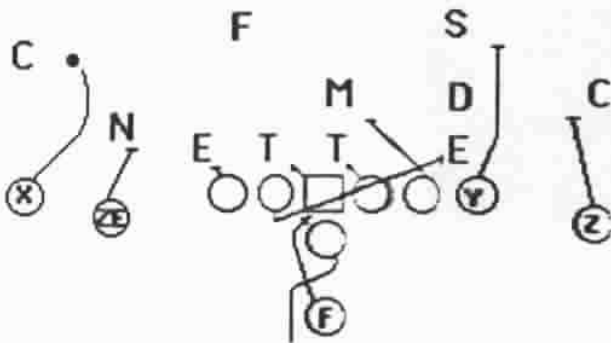

(ZEB) DOUBLE WING RIGHT 60 TRAP

41 QUEEN

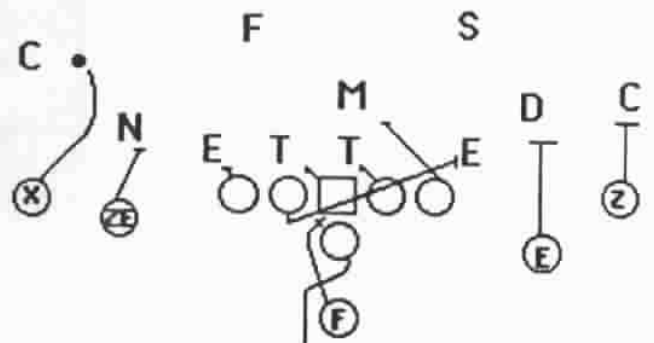

(EAG) SPREAD RIGHT 60 TRAP

Mini Camp - Day 5

RED ZONE PASSES:

+20

- | | |
|--------------------------------------|------------------------------|
| 2-3 JET DINO 'Y' SHALLOW CROSS | -- HB SHIFT TO FAR WEST SLOT |
| 2-3 JET ALL GO SPECIAL
(FK. FB40) | -- (ZEB) TRIPS |
| 2-3 JET 'FLK' DRIVE | -- BLUE 'Y' SHORT |
| 2-3 JET DBL CROSS HB BURST | -- (ZEB) TRIPS |
| 22-23 'Y' STICK | -- BROWN 'B' STRONG |

+15

- | | |
|-------------------------|-----------------------------|
| 22-23 'E' BAKE FB FLAT | -- (E) RED 'E' MOTION |
| 22-23 'X' SHALLOW CROSS | -- BROWN 'A-C' STRONG |
| 2-3 JET SCAT HB OPTION | -- DBL WING SWITCH |
| 20-21 BINGO BACKS LT/RT | -- 'Y' SHIFT TO RED |
| 22 SNAKE FB FLAT | -- RED RIGHT SLOT 'F' RIGHT |

+10

- | | |
|-------------------------------|--------------------------------------|
| 200 JET DBL POST 'Z' COLORADO | -- (T) SOLO LEFT 'X' 'U' LEFT |
| 2 JET 'ZEB' SEAM | -- (ZEB) DBL WING LEFT
'ZEB' LEFT |
| 2-3 JET RATTLER (FK. FB40) | -- BLUE 'Y' SHORT |
| 22-23 SCAT TEXAS 'Y' CROSS | -- HB WEST 'EB' WEAK |
| 22 SCAT 'Z' OPTION | -- DBL WING RIGHT SWITCH |

+5

- | | |
|------------------------------|-------------------------------|
| 324-325 D.Q. FLY / VENUS | -- RED |
| 322 SCAT 'Y' STICK NOD | -- (T) SOLO RT. SLOT 'A' RT. |
| 300 JET 'Y' QK. FLY DBL POST | -- BLUE LT. SLOT OPEN 'A' RT. |
| 200 JET SNAKE 'X' COLORADO | -- (T) EAST LEFT |
| 3 JET FLK ARROW 'HB' QUICK | -- BROWN RIGHT 'A' RIGHT |

(ZEB) TRIPS RIGHT
2 JET ALL GO SPECIAL (FK FB40)

RED ZONE

(E) RED RIGHT 'E' MOTION
22 'E' BAKE FB FLAT (12)

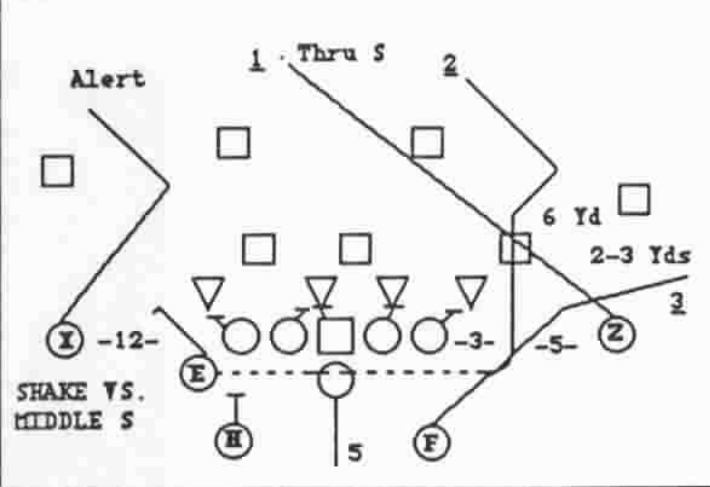
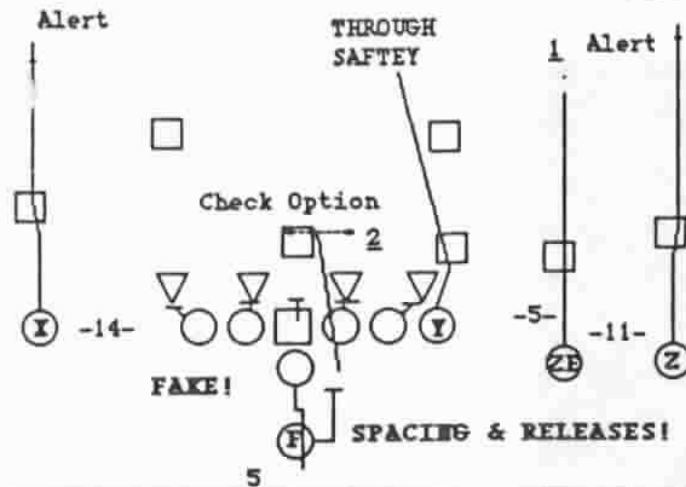

BROWN RIGHT 'A' RIGHT
22 'X' SHALLOW CROSS

+15

RED RIGHT SLOT 'F' RIGHT
22 SNAKE FB FLAT

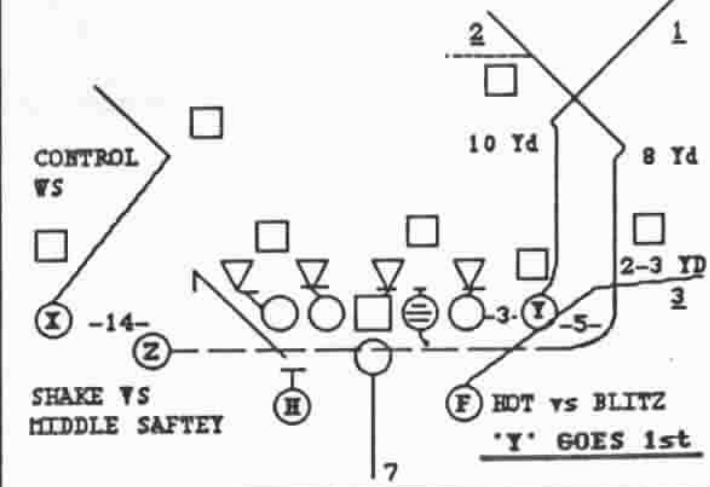
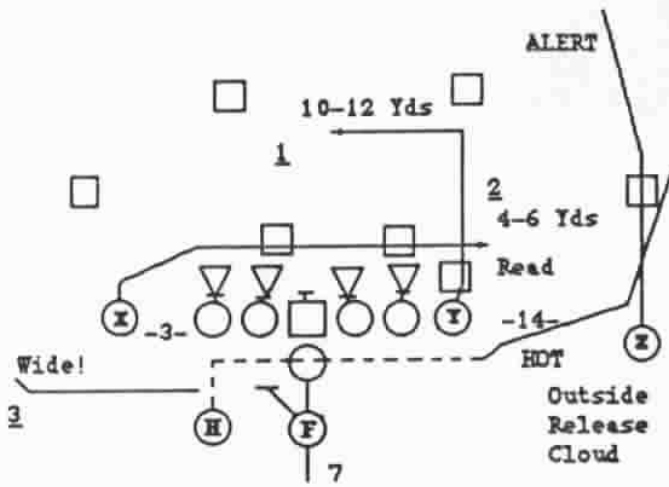

(T) SOLO LEFT 'X' 'U' LEFT
200 JET DOUBLE POST 'Z' COLORADO

+10

(ZEB) DOUBLE WING LEFT 'ZEB' LEFT
2 JET 'ZEB' SEAM

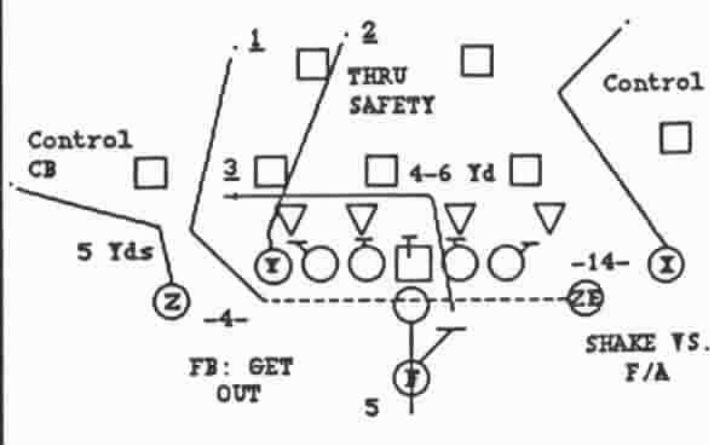
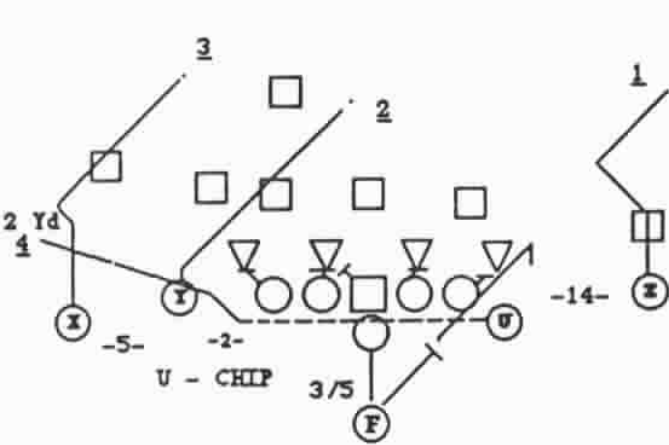

BLUE RIGHT 'Y' SHORT
2 JET RATTLER (FK. FB40)

RED ZONE

DOUBLE WING RIGHT SWITCH
22 SCAT 'Z' OPTION

(13)

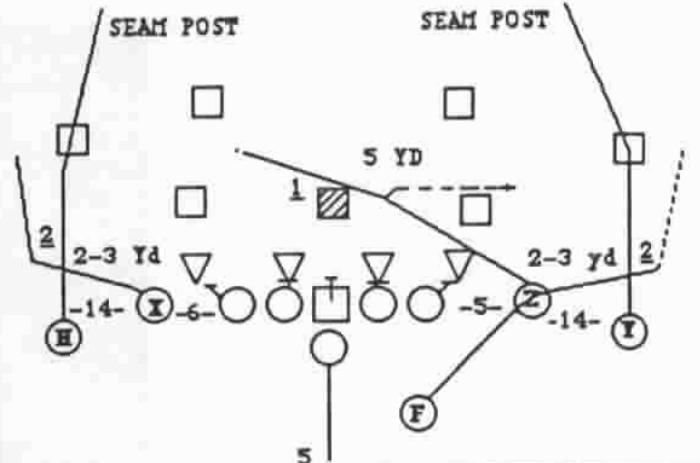
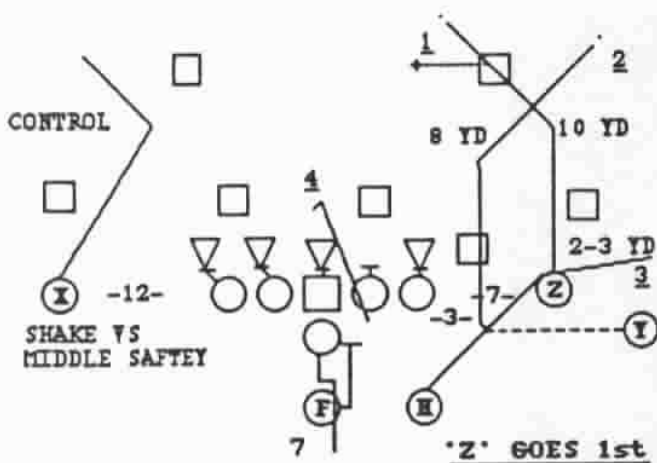

+5

RED RIGHT
324 DOUBLE QUICK FLY/VENUS

(T) SOLO RIGHT SLOT 'A' RIGHT
322 SCAT 'Y' STICK NOD

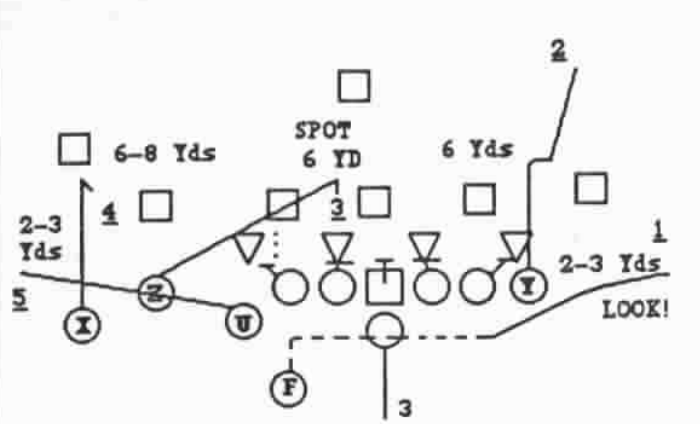
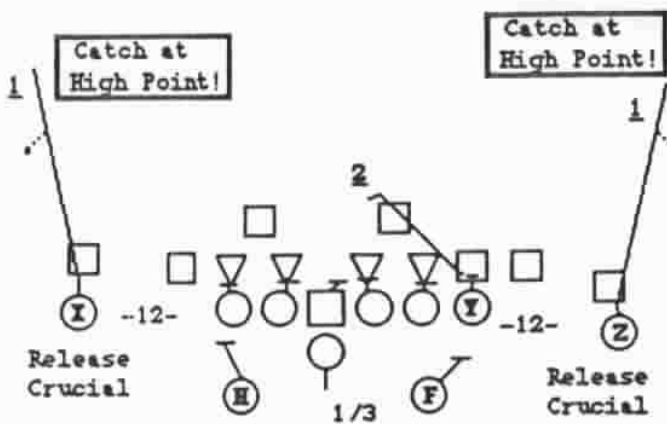

+5

BLUE LEFT SLOT OPEN 'A' RIGHT
300 JET 'Y' QUICK FLY DOUBLE POST

(T) EAST LEFT
200 JET SNAKE 'X' COLORADO

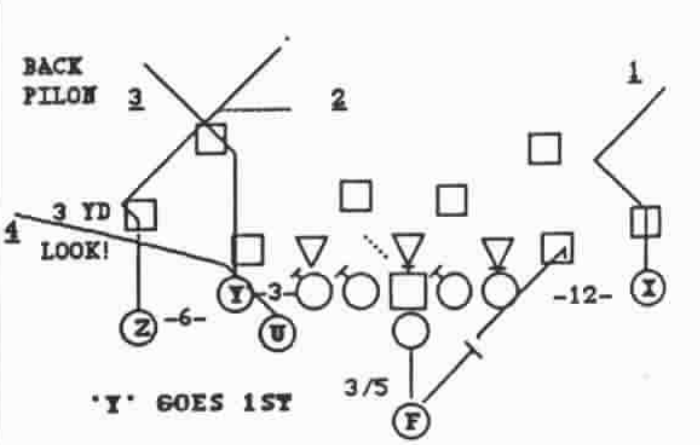
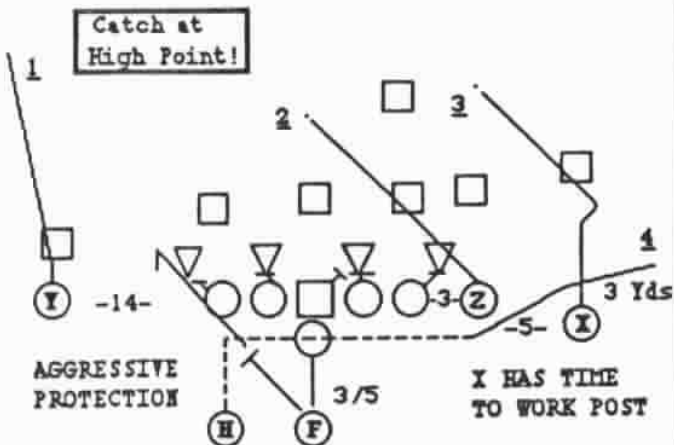

RED ZONE

BROWN RIGHT "A" RIGHT
3 JET 'FLK' ARROW 'HB' QUICK

+5

ALERT

ALERT

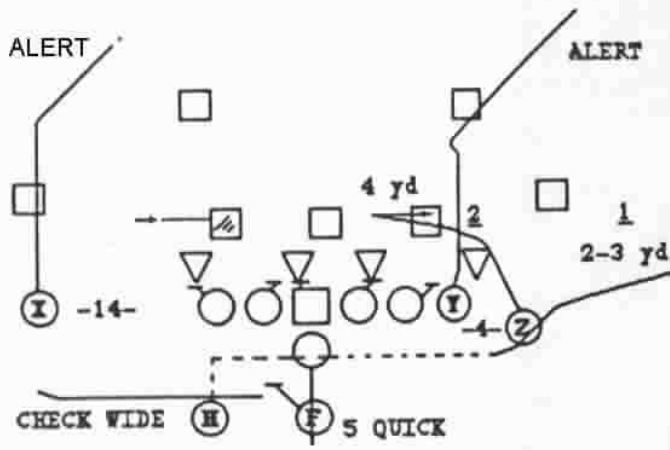

RED RIGHT ZOOM SHORT
50 Y SPOT FLK CROSS

BASE

(U) BLUE RIGHT EAST (15)
200 JET 'Z' SLANT/OM/TH/SM/SL/SLUGGO STOP

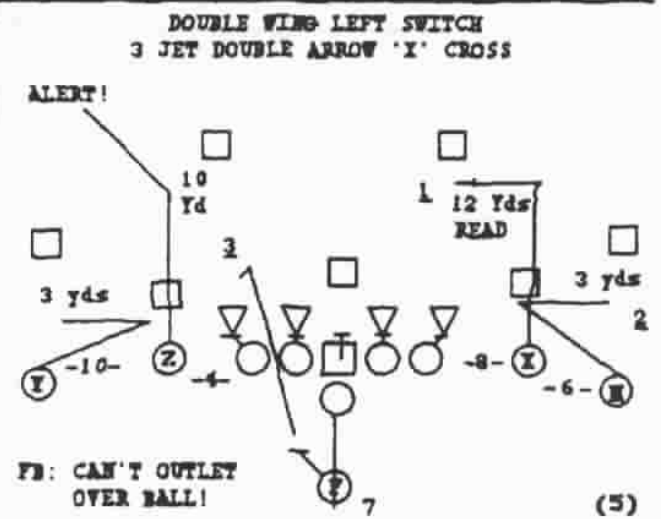
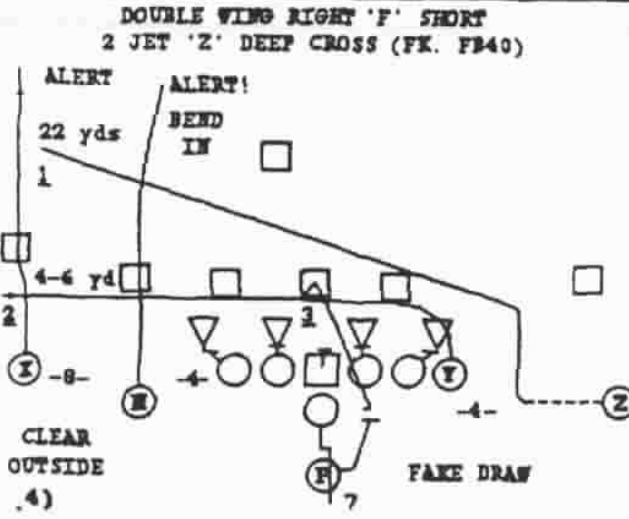
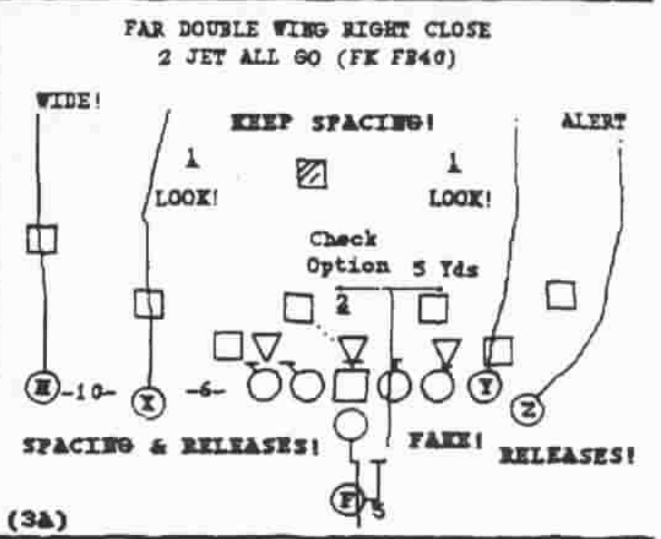
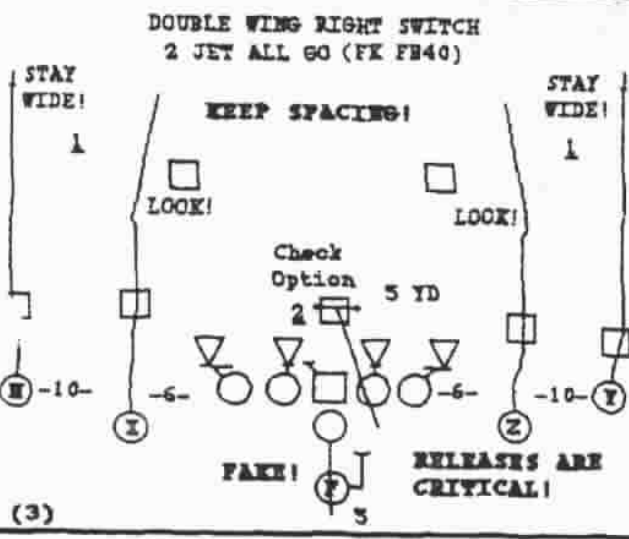
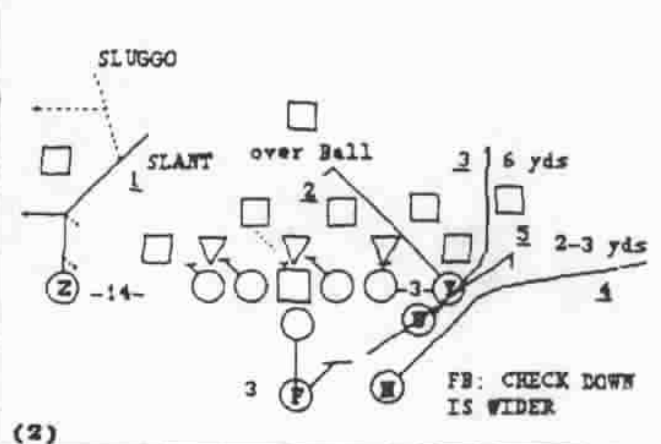
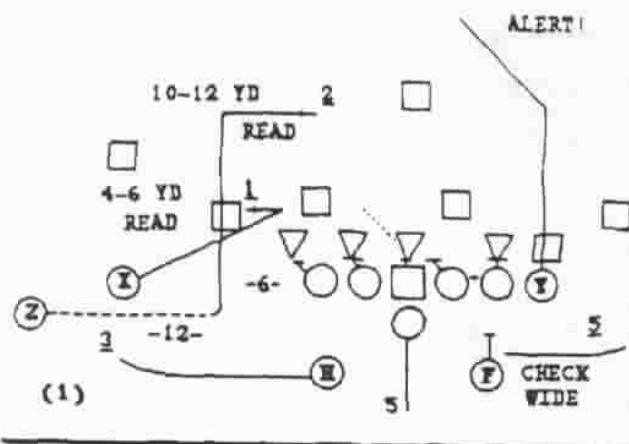

**BROWN RIGHT
FOX 2 'X' 'Y' HOOK**

PLAY PASS

**GREEN RIGHT
FOX 2 'X' 'Y' HOOK**

(16)

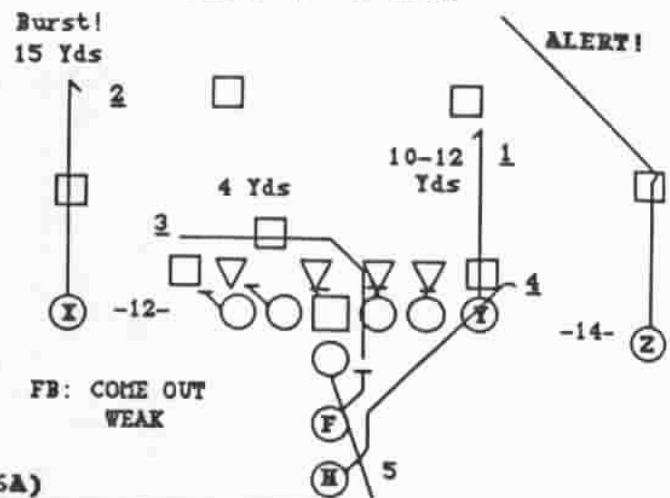
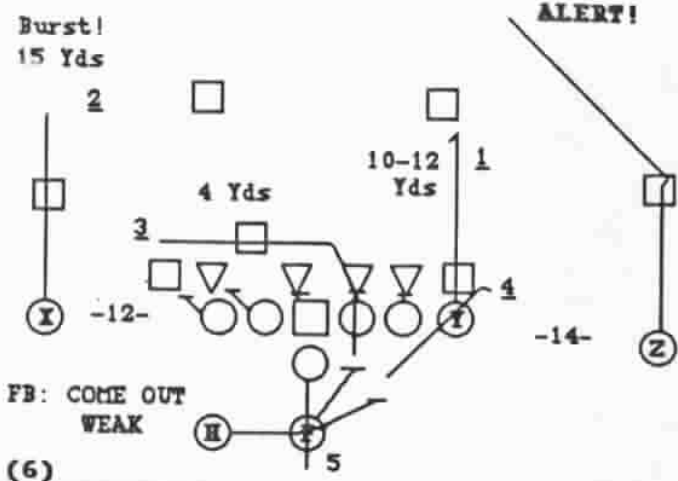

**GREEN LEFT FLASH
P. 312 WEAK DOUBLE QUICK HITCH**

**GREEN LEFT SLOT FLASH
P. 312 WEAK DOUBLE QUICK HITCH**

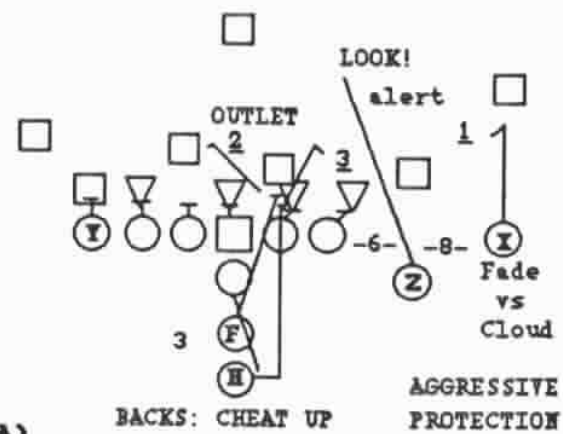
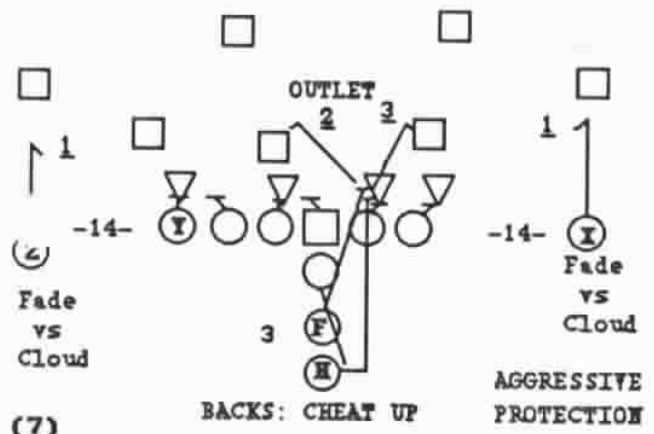

MOVEMENT

**RED LEFT SLOT
SPRINT RIGHT OPTION**

SCREENS

**HB NORTH LEFT 'HB' LEFT
23 'X' SHALLOW CROSS FB SLOW SCREEN RIGHT**

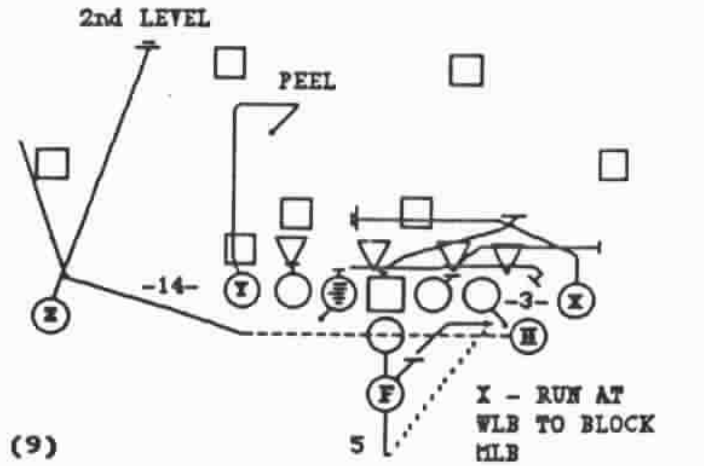
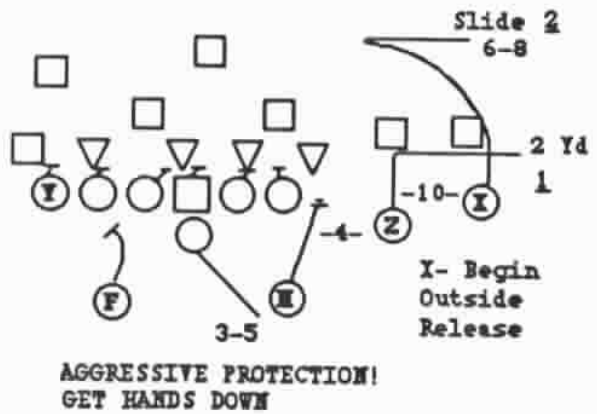

57

62-63 COUNTER

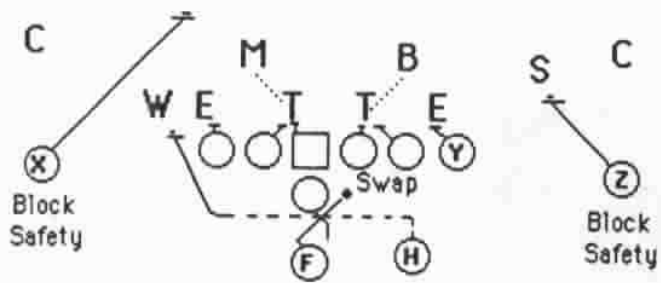

BLUE RIGHT "C" LEFT 62 COUNTER

59

62-63 COUNTER



(T) SOLO RIGHT 62 COUNTER

25

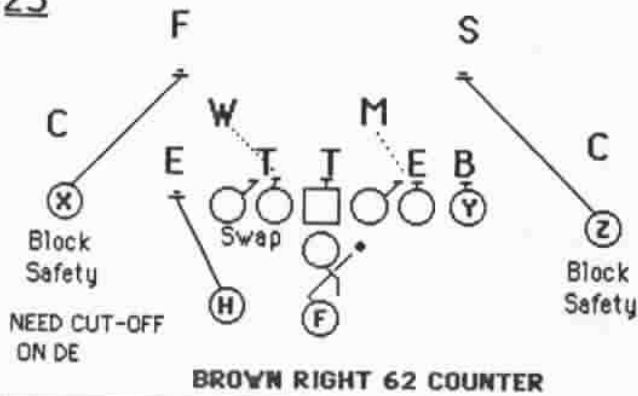

BROWN RIGHT 62 COUNTER

25

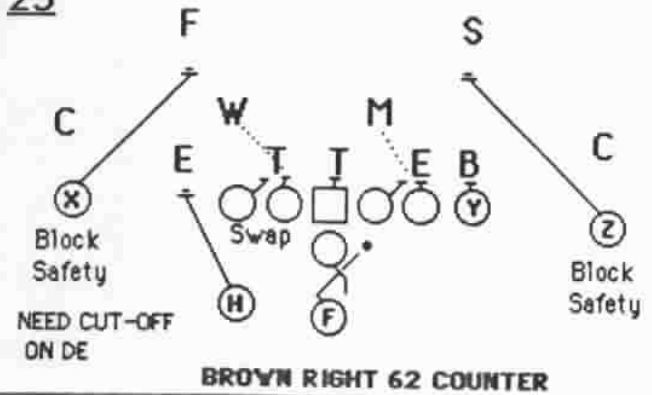

BROWN RIGHT 62 COUNTER

59

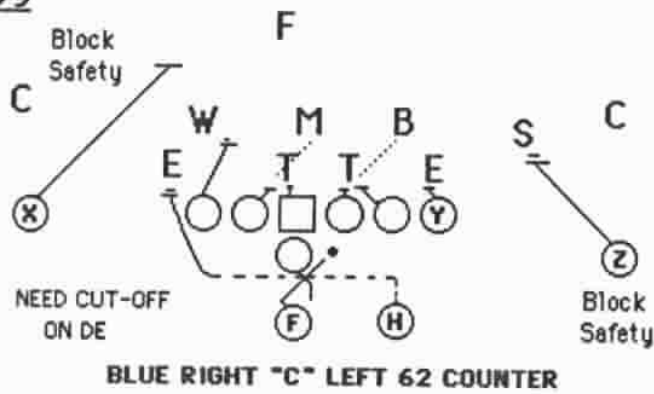

BLUE RIGHT "C" LEFT 62 COUNTER

57

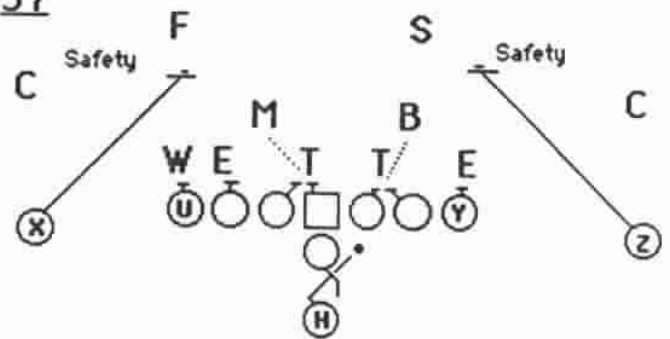

(T) SOLO RIGHT 62 COUNTER

49

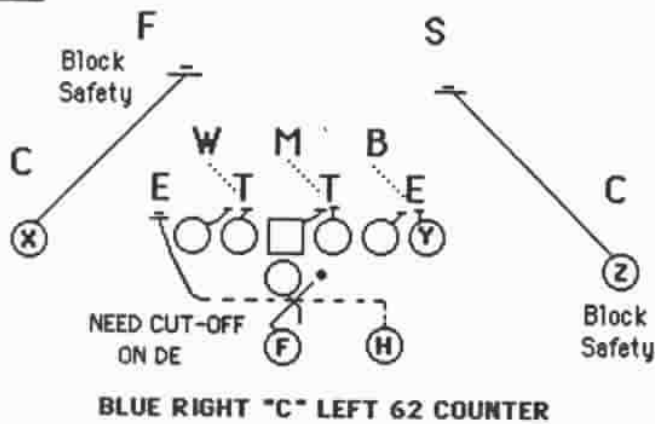

BLUE RIGHT "C" LEFT 62 COUNTER

49

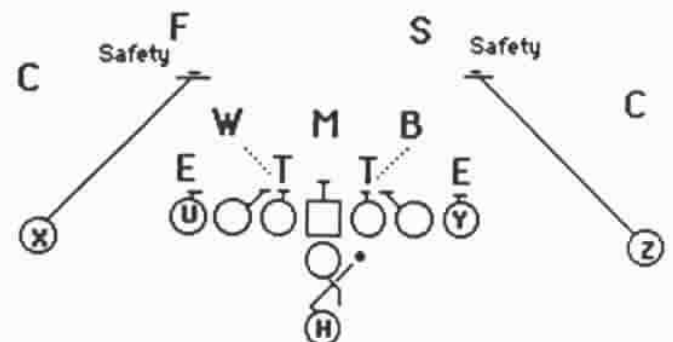

(T) SOLO RIGHT 62 COUNTER

Mini Camp - Day 7

BASE PASSES:

1. 3 JET 'FLK' ARROW HB QUICK -- BLUE RIGHT 'Y' SHORT
2. 2-3 JET DBL 'Z' -- DBL WING SWITCH
3. 2-3 JET 'Z' DAGGER -- (ZEB) TRIPS

PLAY PASSES:

4. FOX 2 WEAK WINSTON -- GREEN LEFT SLOT
5. FOX 2 WEAK 'X' S.O. (& GO) -- GREEN LEFT / BLUE LEFT
6. P. FB @ 0 D.Q.H. -- BROWN RIGHT SLOT 'A' RIGHT

SCREEN PASSES:

7. 2-3 JET FB SL SCREEN STRONG -- BLUE 'Y' SHORT
(OFF 'FLK' DRIVE)
8. 2-3 JET FB SL SCREEN WEAK -- DBL WING SWITCH 'X' STRONG

SPECIALS:

9. FK. 94 FLEA FLICKER -- (T) SOLO RIGHT

RUNS:

1. H-2 SPLIT JOKER -- GREEN RIGHT
2. FK. 18-19 BOB 'Z' REVERSE -- RED

BLUE RIGHT 'Y' SHORT
3 JET FLANKER ARROW HB QUICK

BASE

DOUBLE WING LEFT SWITCH
3 JET DOUBLE 'Z'

(18)

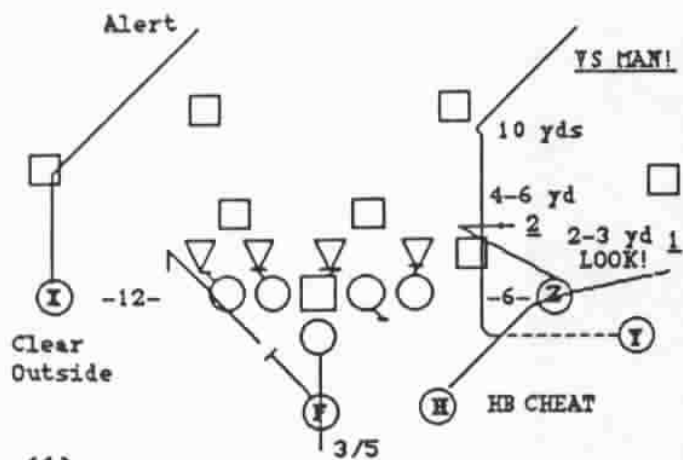

(1)

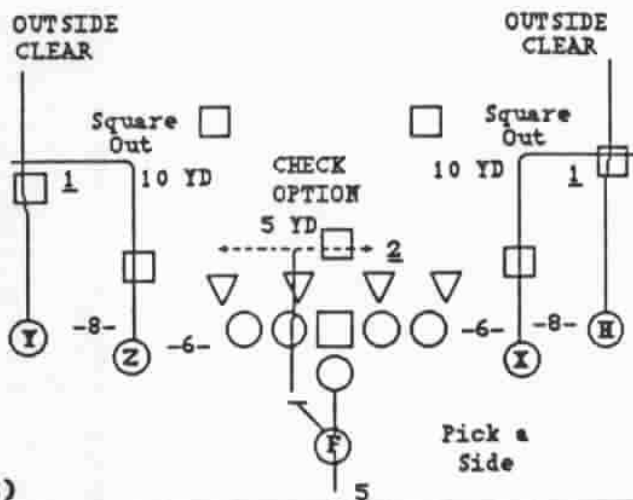

(2)

(ZEB) TRIPS RIGHT
2 JET 'Z' DAGGER (FK FB40)

PLAY PASS

GREEN LEFT SLOT
FOX 2 WEAK WINSTON

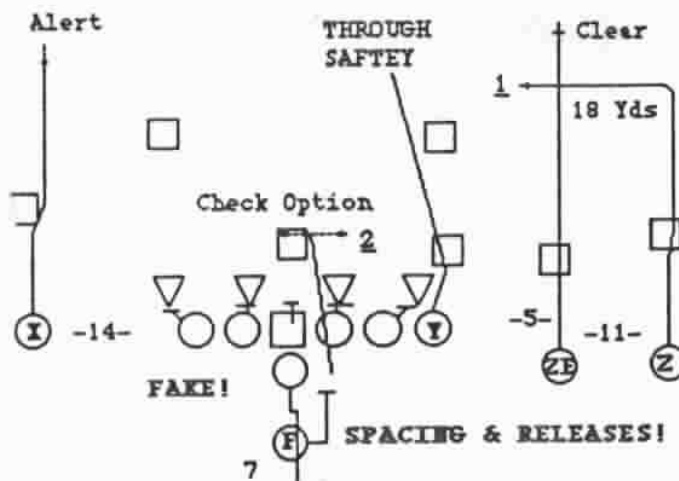

(3)

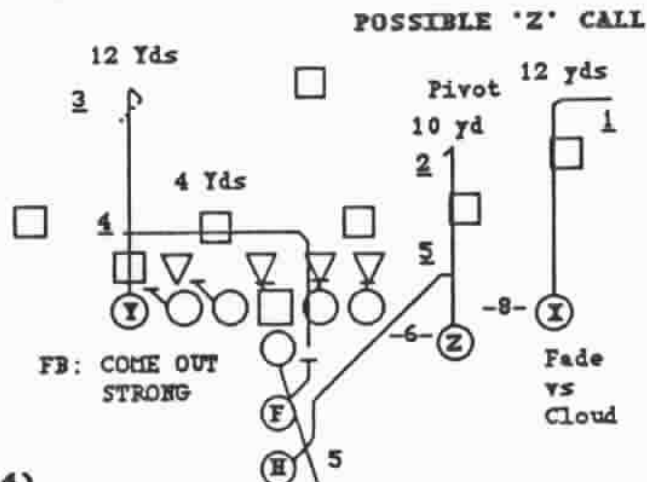

(4)

GREEN LEFT
FOX 2 WEAK 'X' SQUARE OUT (& GO)

BLUE LEFT
FOX 2 WEAK 'X' SQUARE OUT (& GO)

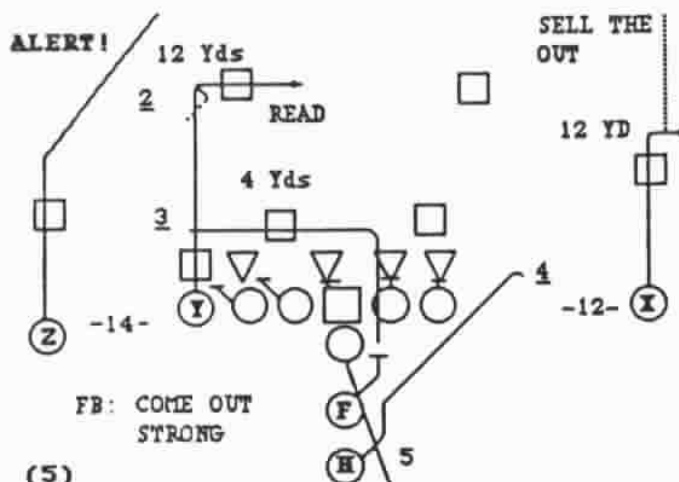

(5)

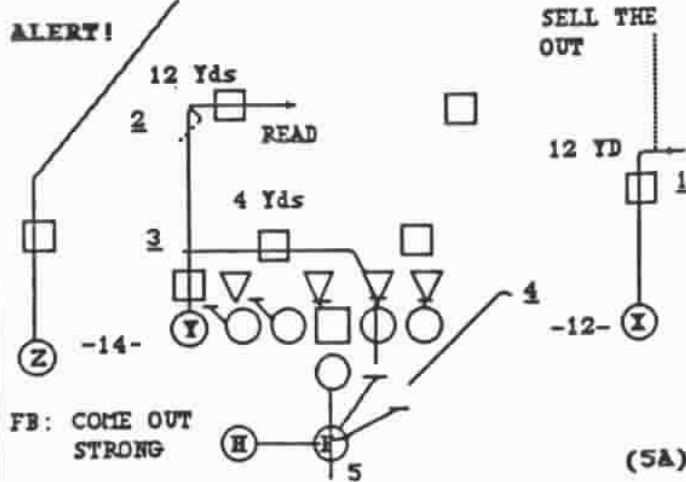

(5A)

PLAY PASS

BROWN RIGHT SLOT 'A' RIGHT
P. FB @ 0 DOUBLE QUICK HITCH

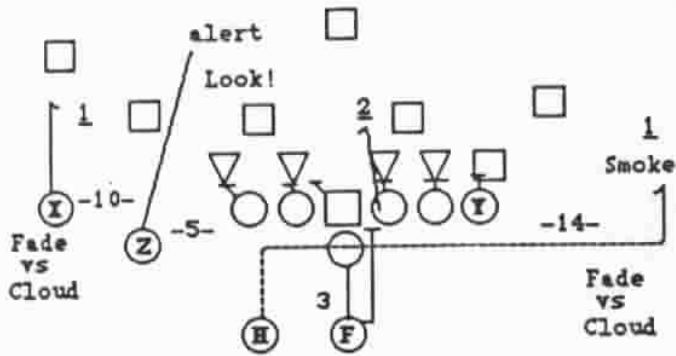

(6)

SCREENS

(19)

BLUE RIGHT 'Y' SHORT
2 JET FB SLOW SCREEN RIGHT

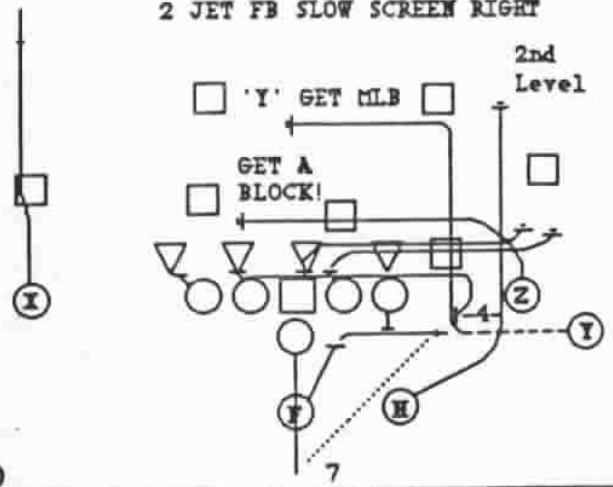

(7)

DOUBLE WING RIGHT SWITCH 'X' RIGHT
2 JET FB SLOW SCREEN LEFT

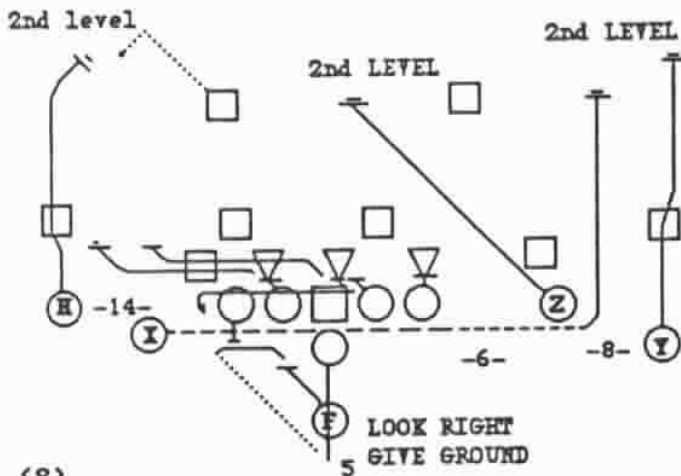

(8)

SPECIALS

(T) SOLO RIGHT
FAKE 94 FLEA FLICKER

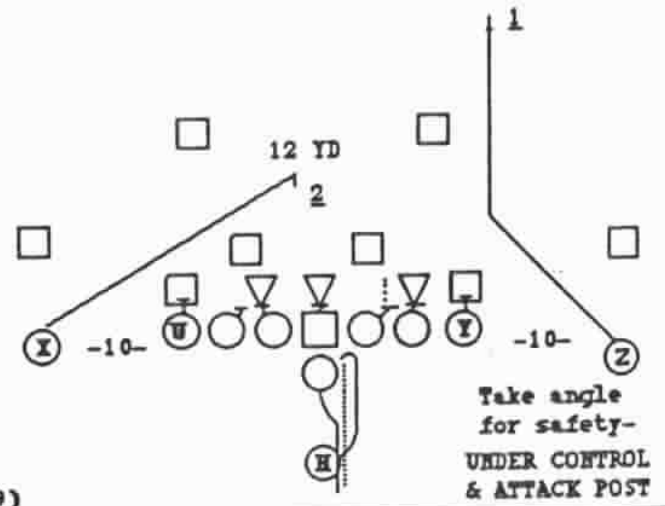

(9)

C 34

H2-3 SPLIT JOKER

F 57(37)

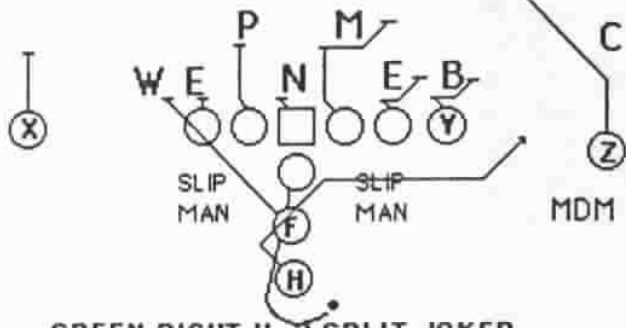

GREEN RIGHT H-2 SPLIT JOKER

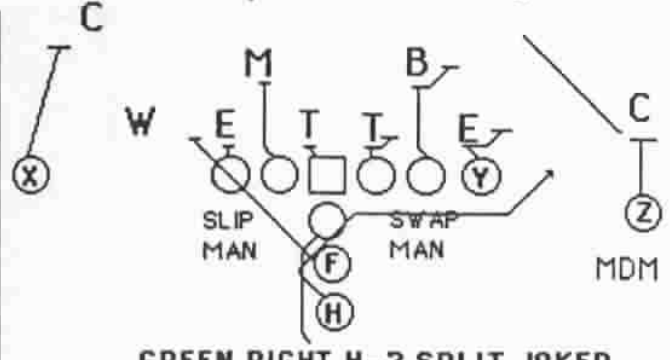

GREEN RIGHT H-2 SPLIT JOKER

25(35)

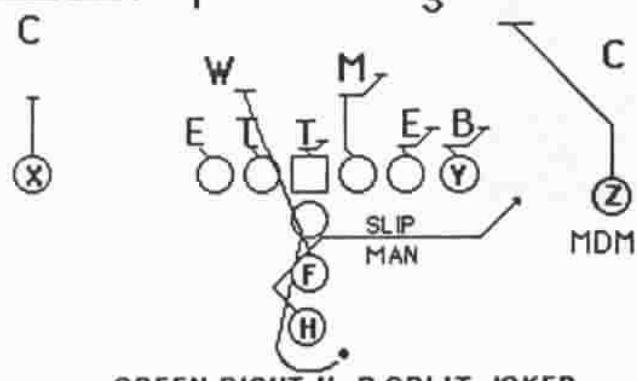

GREEN RIGHT H-2 SPLIT JOKER

49



GREEN RIGHT H-2 SPLIT JOKER

25

FK 18-19 BOB Z REVERSE

57

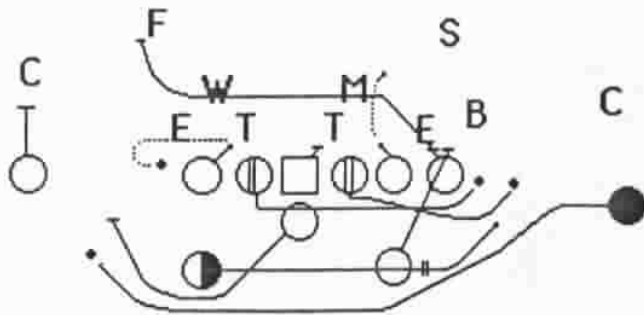

RED RIGHT FK 18 BOB 'Z' REVERSE LEFT

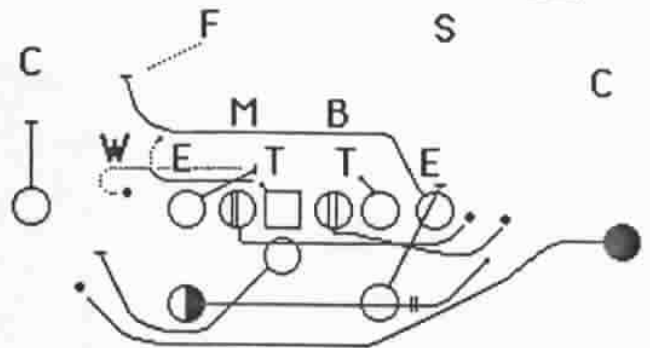

RED RIGHT FK 18 BOB 'Z' REVERSE LEFT

59

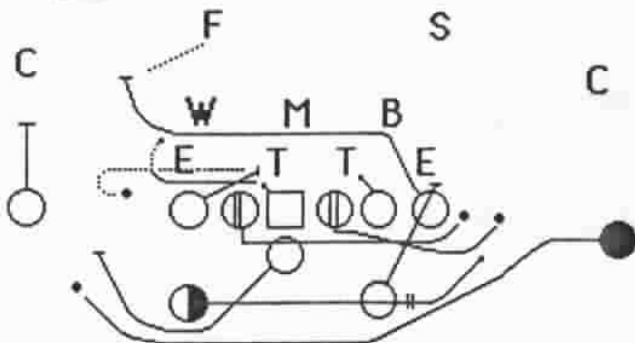

RED RIGHT FK 18 BOB 'Z' REVERSE LEFT

49

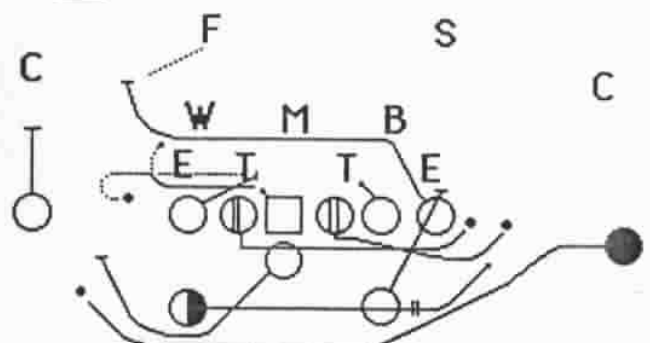

RED RIGHT FK 18 BOB 'Z' REVERSE LEFT